

# THE ARCOY DOVETAILER

Information assembled and edited by  
**John Luby**  
([www.jluby.org.uk/arcoy](http://www.jluby.org.uk/arcoy))

---

Now out of production, the Arcoy Dovetailer is still in use in thousands of workshops.  
As they change hands over the years, the instructions do not always survive, which is the reason for these pages.

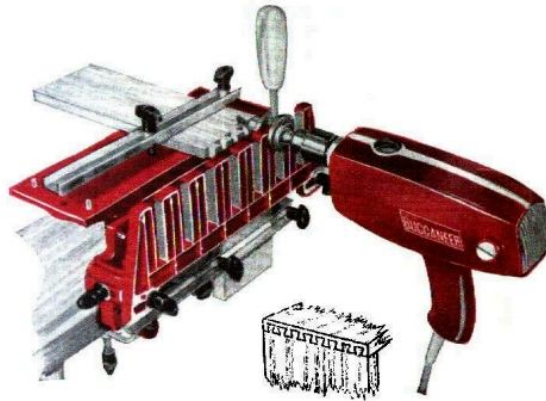

**THESE PAGES ARE FOR INFORMATION ONLY.  
ANY AND ALL USE OF THESE INSTRUCTIONS, THE EQUIPMENT SHOWN, OR ANY  
MODIFICATIONS, ARE UNDERTAKEN ENTIRELY UPON THE USER'S RESPONSIBILITY  
AND AT THE USER'S OWN RISK.**

This information is provided for those with Arcoy Dovetailers who lack the instructions.

Anything on this website reproduced from original Arcoy artwork or text may still be the copyright of the original manufacturer.

All else on my website or in this document is copyright of John Luby and may not be reproduced without permission.  
That permission is almost always given - the only requirement is good manners.

Please remember that all woodworking machinery is potentially dangerous, and all necessary precautions should be taken in its use. Particular care should be taken to provide proper eye and respiratory protection, and where guards are necessary, these should be fitted and used.

---

## PRICES AND SPARE PARTS:

I'm regularly asked for sources of spare parts for the Arcoy Dovetailer, or information on third-party engineering services who might make up parts. I'm afraid to date I've found no sources, and cannot help with such queries.

Nor can I help with valuations or pricing. Along with the fact I make no claims to expertise, only enthusiasm, on Arcoy matters, I'm afraid the appearance over the last few years of literally thousands of old tools on websites like eBay has meant that prices have plummeted. If you have an old Arcoy Dovetailer, it's worth what someone will give you for it, and that amount may be anyone's guess. That isn't sarcasm, it's a fact of life I'm sorry to say - but it's often good news for buyers, if for no-one else.

I'm afraid that emails requesting valuations, buying or selling advice further to that given elsewhere on my website, or sources for the device or its spares will simply not be answered.

We have to accept that any further production of Arcoy spares, especially in single units or low volume, is unlikely - it's just not commercially viable these days. Where spares have been manufactured in the past in small workshops, it's invariably been as a personal project or a favour for a friend. I'm afraid in these days of £20 electric routers and £40 dovetail templates, we just have to accept that the Arcoy Dovetailer has been overtaken by progress.

Despite this, few people who use the Arcoy Dovetailer have the heart to retire it or dispose of it. It's a testimony - a relic if you want to be cynical - of the days when engineering excellence came first. Please keep these machines going - they pine if they're left idle.

### Bench Drill Stand

Any of the Arcoy range of power drills and most other tools will fit on this sturdy, adjustable stand. It is built with 1 1/2" diameter chrome-plated steel and is available in three sizes to suit the different tools. It is designed to be used on a workbench or in a workshop. It is available in three sizes to suit the different tools. It is designed to be used on a workbench or in a workshop.

**Model and Price:**  
 CAT. NO. 204 £13.58 (£12.79)  
 CAT. NO. 205 £15.58 (£14.79)  
 CAT. NO. 203 £11.58 (£10.79)

**Drill Stand only.**



### Standard Dovetailer

The Dovetailer has been developed for use with any Electric Dovetailer from Power's Universal Motor, giving maximum accuracy and speed. It is available in three sizes to suit the different tools. It is designed to be used on a workbench or in a workshop.

**Model and Price:**  
 CAT. NO. 118 (£10.75)

### Housing Joint Attachment

An extra set of jaws which allows Housing Joints to be cut rapidly and accurately on any of the 22 dovetailer models. The same jaws suggested with the Standard Dovetailer will also work for each of these attachments.

**Model and Price:**  
 CAT. NO. 119 (£2.98)

### Multi-Pitch Attachment

Provides four additional patterns, 1/4", 1/2", 3/4" and 1" (13, 16, 19 and 25 mm) for cutting dovetail joints. It is available in three sizes to suit the different tools. It is designed to be used on a workbench or in a workshop.

**Model and Price:**  
 CAT. NO. 120 (£4.00)

### ARCOY DOVETAILED CUTTERS TO BE EACH

FOR USE WITH STANDARD DOVETAILEDER

### Extra Power Drill Accessories

CAT. NO. 206 £11.58 (£10.79)  
 CAT. NO. 207 £12.58 (£11.79)  
 CAT. NO. 208 £13.58 (£12.79)  
 CAT. NO. 209 £14.58 (£13.79)  
 CAT. NO. 210 £15.58 (£14.79)

### Power Plane Accessories

CAT. NO. 211 £11.58 (£10.79)  
 CAT. NO. 212 £12.58 (£11.79)  
 CAT. NO. 213 £13.58 (£12.79)  
 CAT. NO. 214 £14.58 (£13.79)  
 CAT. NO. 215 £15.58 (£14.79)

### FACTORY SERVICING

For all repairs to your Arcoy Power Tools, contact your nearest Arcoy Power Tools agent. If you are unable to contact your agent, please write to: Arcoy Power Tools, 150, 152, 154, 156, 158, 160, 162, 164, 166, 168, 170, 172, 174, 176, 178, 180, 182, 184, 186, 188, 190, 192, 194, 196, 198, 200, 202, 204, 206, 208, 210, 212, 214, 216, 218, 220, 222, 224, 226, 228, 230, 232, 234, 236, 238, 240, 242, 244, 246, 248, 250, 252, 254, 256, 258, 260, 262, 264, 266, 268, 270, 272, 274, 276, 278, 280, 282, 284, 286, 288, 290, 292, 294, 296, 298, 300, 302, 304, 306, 308, 310, 312, 314, 316, 318, 320, 322, 324, 326, 328, 330, 332, 334, 336, 338, 340, 342, 344, 346, 348, 350, 352, 354, 356, 358, 360, 362, 364, 366, 368, 370, 372, 374, 376, 378, 380, 382, 384, 386, 388, 390, 392, 394, 396, 398, 400, 402, 404, 406, 408, 410, 412, 414, 416, 418, 420, 422, 424, 426, 428, 430, 432, 434, 436, 438, 440, 442, 444, 446, 448, 450, 452, 454, 456, 458, 460, 462, 464, 466, 468, 470, 472, 474, 476, 478, 480, 482, 484, 486, 488, 490, 492, 494, 496, 498, 500, 502, 504, 506, 508, 510, 512, 514, 516, 518, 520, 522, 524, 526, 528, 530, 532, 534, 536, 538, 540, 542, 544, 546, 548, 550, 552, 554, 556, 558, 560, 562, 564, 566, 568, 570, 572, 574, 576, 578, 580, 582, 584, 586, 588, 590, 592, 594, 596, 598, 600, 602, 604, 606, 608, 610, 612, 614, 616, 618, 620, 622, 624, 626, 628, 630, 632, 634, 636, 638, 640, 642, 644, 646, 648, 650, 652, 654, 656, 658, 660, 662, 664, 666, 668, 670, 672, 674, 676, 678, 680, 682, 684, 686, 688, 690, 692, 694, 696, 698, 700, 702, 704, 706, 708, 710, 712, 714, 716, 718, 720, 722, 724, 726, 728, 730, 732, 734, 736, 738, 740, 742, 744, 746, 748, 750, 752, 754, 756, 758, 760, 762, 764, 766, 768, 770, 772, 774, 776, 778, 780, 782, 784, 786, 788, 790, 792, 794, 796, 798, 800, 802, 804, 806, 808, 810, 812, 814, 816, 818, 820, 822, 824, 826, 828, 830, 832, 834, 836, 838, 840, 842, 844, 846, 848, 850, 852, 854, 856, 858, 860, 862, 864, 866, 868, 870, 872, 874, 876, 878, 880, 882, 884, 886, 888, 890, 892, 894, 896, 898, 900, 902, 904, 906, 908, 910, 912, 914, 916, 918, 920, 922, 924, 926, 928, 930, 932, 934, 936, 938, 940, 942, 944, 946, 948, 950, 952, 954, 956, 958, 960, 962, 964, 966, 968, 970, 972, 974, 976, 978, 980, 982, 984, 986, 988, 990, 992, 994, 996, 998, 1000.

### Your local ARCOY Stockist is:

Slide and Barnes - Arcoy Products Ltd.  
 Assembly Road, Benth, 128 12C, Luton, England.

NOTE: All Arcoy tools are made in Great Britain and are guaranteed for 12 months.

### The Mark II Power Plane

CAT. NO. 200 £14.58 (£13.79)

For maximum performance, the Mark II Power Plane has been designed with a new, more powerful motor and a new, more efficient gear train. It is available in three sizes to suit the different tools. It is designed to be used on a workbench or in a workshop.

### Power Plane Accessory Kit

CAT. NO. 201 £11.58 (£10.79)

For maximum performance, the Power Plane Accessory Kit includes a new, more powerful motor and a new, more efficient gear train. It is available in three sizes to suit the different tools. It is designed to be used on a workbench or in a workshop.

### Bench Clamp Kit

CAT. NO. 202 £11.58 (£10.79)

For maximum performance, the Bench Clamp Kit includes a new, more powerful motor and a new, more efficient gear train. It is available in three sizes to suit the different tools. It is designed to be used on a workbench or in a workshop.

### THIS IS THE SINGLE MOST IMPORTANT TOOL FOR YOUR DEVELOPMENT!

For maximum performance, this tool includes a new, more powerful motor and a new, more efficient gear train. It is available in three sizes to suit the different tools. It is designed to be used on a workbench or in a workshop.

### Buccaneer Drills—star features

- ★ All Buccaneer drills are built with a new, more powerful motor and a new, more efficient gear train.
- ★ 1 1/2" chuck for extra power.
- ★ V-shaped commutators for extra speed.
- ★ Heavy standard motor windings for extra life.
- ★ Back-rod motor mounting for extra stability.
- ★ Gear box sealed for life.
- ★ New Extra-Load and Extra-Stroke bearings for extra performance and longer life.

### RECOMMENDED SPEED & POWER

CAT. NO. 203 £11.58 (£10.79)  
 CAT. NO. 204 £13.58 (£12.79)  
 CAT. NO. 205 £15.58 (£14.79)

### Orbital Sander Attachment

CAT. NO. 206 £11.58 (£10.79)

For maximum performance, the Orbital Sander Attachment includes a new, more powerful motor and a new, more efficient gear train. It is available in three sizes to suit the different tools. It is designed to be used on a workbench or in a workshop.

### Hedge Trimmer Attachment

CAT. NO. 207 £12.58 (£11.79)

For maximum performance, the Hedge Trimmer Attachment includes a new, more powerful motor and a new, more efficient gear train. It is available in three sizes to suit the different tools. It is designed to be used on a workbench or in a workshop.

### GENERAL SPECIFICATION

For maximum performance, all Buccaneer drills are built with a new, more powerful motor and a new, more efficient gear train. It is available in three sizes to suit the different tools. It is designed to be used on a workbench or in a workshop.

### RECOMMENDED SPEED & POWER

CAT. NO. 208 £13.58 (£12.79)  
 CAT. NO. 209 £14.58 (£13.79)  
 CAT. NO. 210 £15.58 (£14.79)

### 6" Saw Attachment

CAT. NO. 211 £11.58 (£10.79)

For maximum performance, the 6" Saw Attachment includes a new, more powerful motor and a new, more efficient gear train. It is available in three sizes to suit the different tools. It is designed to be used on a workbench or in a workshop.

### Arcoy Handyman Kit

CAT. NO. 212 £12.58 (£11.79)

For maximum performance, the Arcoy Handyman Kit includes a new, more powerful motor and a new, more efficient gear train. It is available in three sizes to suit the different tools. It is designed to be used on a workbench or in a workshop.

### REBETTER

CAT. NO. 213 £13.58 (£12.79)

For maximum performance, the Rebetter includes a new, more powerful motor and a new, more efficient gear train. It is available in three sizes to suit the different tools. It is designed to be used on a workbench or in a workshop.

### COMBINATION SAW GUIDE AND PROTRACTOR

CAT. NO. 214 £14.58 (£13.79)

For maximum performance, the Combination Saw Guide and Protractor includes a new, more powerful motor and a new, more efficient gear train. It is available in three sizes to suit the different tools. It is designed to be used on a workbench or in a workshop.

### REBETTER

CAT. NO. 215 £15.58 (£14.79)

For maximum performance, the Rebetter includes a new, more powerful motor and a new, more efficient gear train. It is available in three sizes to suit the different tools. It is designed to be used on a workbench or in a workshop.

### COMBINATION SAW GUIDE AND PROTRACTOR

CAT. NO. 216 £16.58 (£15.79)

For maximum performance, the Combination Saw Guide and Protractor includes a new, more powerful motor and a new, more efficient gear train. It is available in three sizes to suit the different tools. It is designed to be used on a workbench or in a workshop.

## Assembly Instructions

These instructions have been taken from the original Arcoy documents and are shown here for the benefit of current owners. No breach of copyright is intended.

**THESE PAGES ARE FOR INFORMATION ONLY.  
ANY AND ALL USE OF THESE INSTRUCTIONS, THE EQUIPMENT SHOWN, OR ANY MODIFICATIONS,  
ARE UNDERTAKEN ENTIRELY UPON THE USER'S RESPONSIBILITY AND AT THE USER'S OWN RISK.**

Please remember that all woodworking machinery is potentially dangerous, and all necessary precautions should be taken in its use. Particular care should be taken to provide proper eye and respiratory protection, and where guards are necessary, these should be fitted and used.

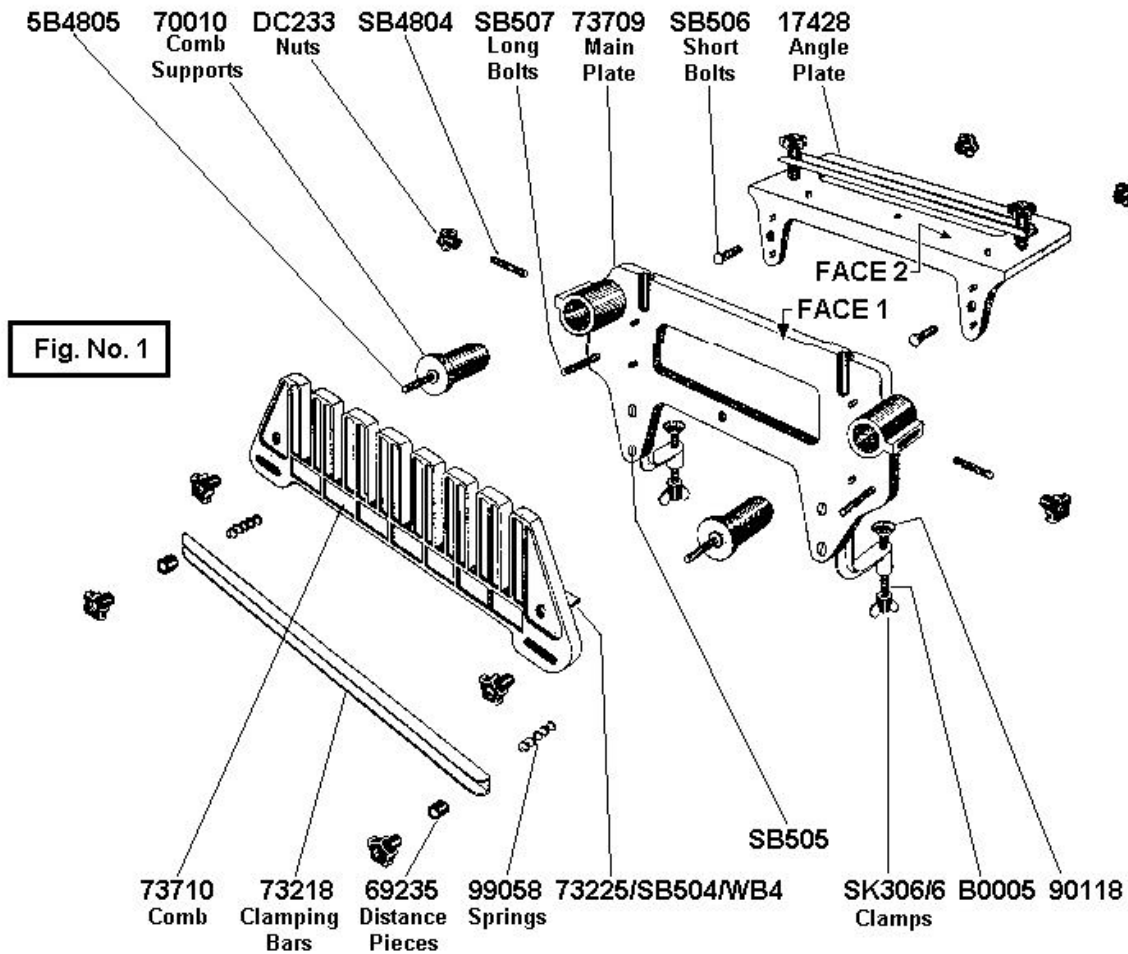

1. Attach Clamps (SK 306/6) to Main Plate (73709) by means of the four countersunk head screws.
2. The pins in the lugs on the Angle Plate (17428) are engaged in the slots on the rear face of the Main Plate. The short bolts (SB 506) are fitted through the slots on the front face of the Main Plate and the bolt holes in the Angle Plate lugs and are secured with nuts (DC 233).
3. The Comb (73710) is fitted over the studs in the Comb Supports (70010), registered in either of the two positions, and secured with nuts.
4. The Clamping Bars (73218) are attached to the Angle Plate and the Main Plate by means of the long bolts (SB 507) and nuts. The Distance Pieces (69235) are interposed between the nuts and the Clamping Bars and the Springs (99058) between the Clamping Bars and the Plates.

# Operating Instructions

These instructions have been taken from the original Arcoy documents and are shown here for the benefit of current owners. No breach of copyright is intended.

**THESE PAGES ARE FOR INFORMATION ONLY.  
ANY AND ALL USE OF THESE INSTRUCTIONS, THE EQUIPMENT SHOWN, OR ANY MODIFICATIONS,  
ARE UNDERTAKEN ENTIRELY UPON THE USER'S RESPONSIBILITY AND AT THE USER'S OWN RISK.**

Please remember that all woodworking machinery is potentially dangerous, and all necessary precautions should be taken in its use. Particular care should be taken to provide proper eye and respiratory protection, and where guards are necessary, these should be fitted and used.

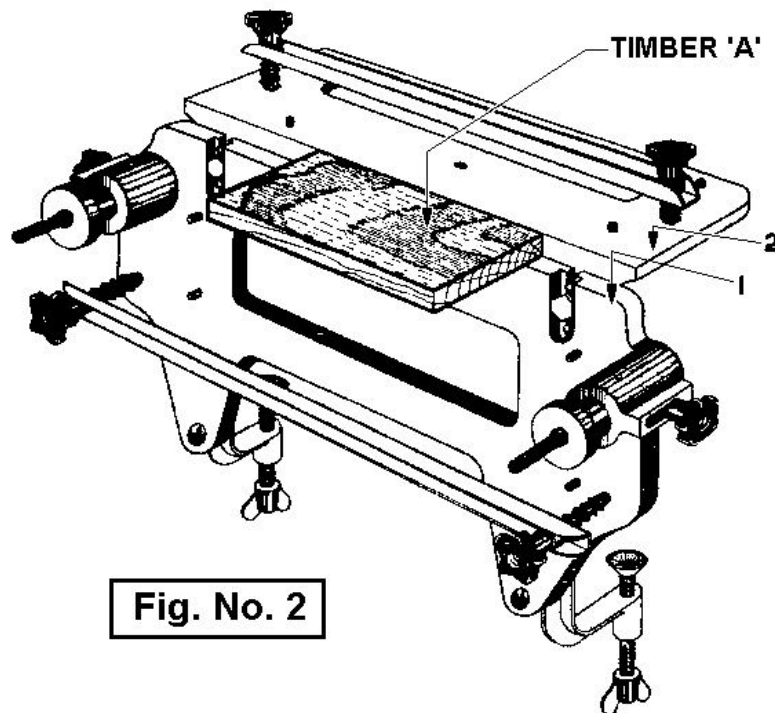

**Before commencing setting up ensure that all timber is both parallel and square.**

1. Remove the Comb.
2. Slacken the nuts securing the Angle Plate to the Main Plate. Adjust the distance between Faces 1 & 2 (Fig. No. 2) until it is equal to the thickness of timber (A) in which the open dovetails are to be cut. The simplest method is to rest the timber on Face 1 and adjust the Angle Plate until the timber is flush with Face 2.

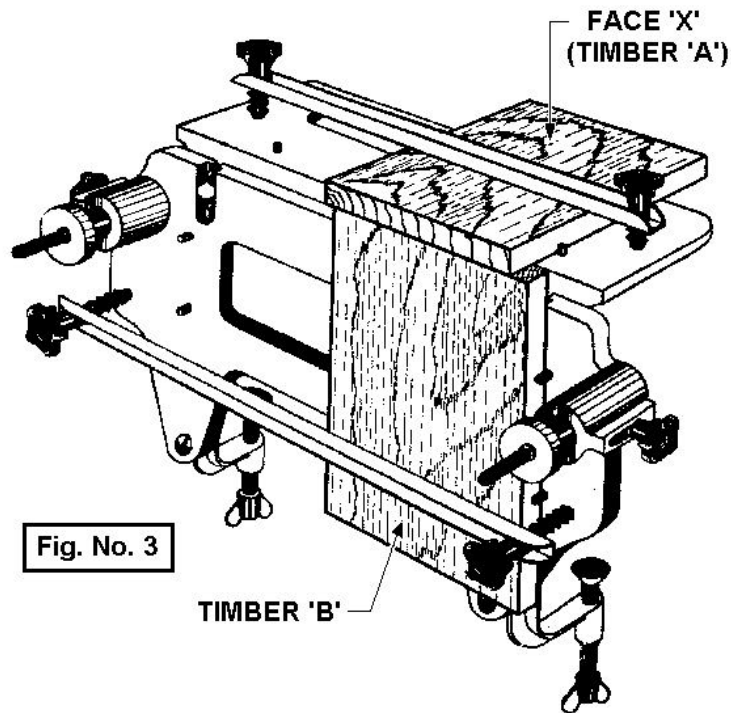

3. Insert the timber under the Clamping Bar on the Angle Plate, push forward till it projects beyond the Main Plate and clamp temporarily.
4. Place the second piece of timber (B), i.e. that in which the blind dovetails are to be cut, on the Main Plate, locate against the setting pins, slide upwards to butt squarely against the underside of timber A and clamp firmly.
5. Slacken the nuts holding timber A, locate against the setting pins on the Angle Plate, set the front edge flush with the front face of timber B and clamp firmly (Fig. No. 3).
6. Replace the Comb, registering in either of the two positions.
7. Slacken the nuts securing the Comb Supports and push the whole Comb Assembly forward in order to butt the Setting Bar against the front face of timber B.
8. Insert the spindle of the Cutter Head into the drill chuck, by reference to the Cutter Chart select the appropriate cutter and, using the spanner provided, screw the cutter into the spindle.
9. Place the Cutter Head in the first slot of the Comb, switch on the drill and, with a light pressure on the handle, guide the Cutter Head easily down the full length of the slot. Repeat in the other slots.
10. Slacken the nuts holding the Comb to its supports and register the Comb in the second position. Tighten the nuts and repeat the cutting operation.

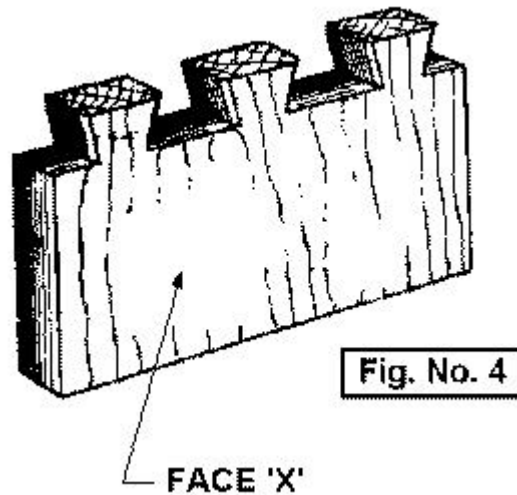

11. Chamfer the tenons on Face X of timber A (Figs. Nos. 3 & 4) to ensure correct seating in the slots. This will only be necessary on very hard woods.
12. When cutting very soft wood with an open grain it is advisable to support the edge of timber A, where it overhangs both the Main Plate and timber B, with scrap material, in order to avoid splintering when the cutter breaks through.
13. The Dovetailer incorporates an adjustment to allow for the cutting of loose or tight, dovetails at will and to compensate for any decrease in the diameter of the cutter due to sharpening. To alter the fit of the joint, release the two screws on the Setting Bar and move the sliding member as indicated by the engraving. Check the adjustment by cutting a joint in scrap timber.

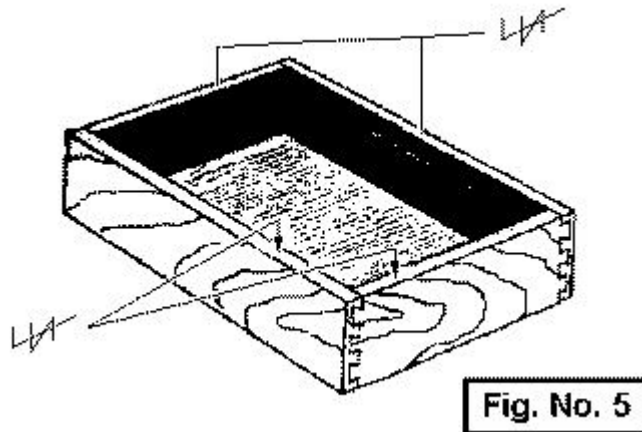

14. To ensure correct line-up of all the timber in a complete structure, such as the sides of a drawer, or box, two sets of setting pins are provided on each plate. It is essential before commencing work to mark the proposed top edges (Fig. 5) and, when setting the timber on the dovetailer, to ensure that the marked edges are always adjacent to setting pins.

To calculate the length of timber required, e.g., drawer sides; subtract from the overall length of side required the combined thickness of the front and back, and add  $\frac{5}{8}$ " for cutter no. 1;  $\frac{7}{8}$ " for cutter no. 2;  $1\text{-}\frac{1}{8}$ " for cutter no. 3.

# CUTTER SELECTION CHART

## for

# STANDARD ARCOY DOVETAILER

These instructions have been taken from the original Arcoy documents and are shown here for the benefit of current owners. No breach of copyright is intended.

**THESE PAGES ARE FOR INFORMATION ONLY.  
 ANY AND ALL USE OF THESE INSTRUCTIONS, THE EQUIPMENT SHOWN, OR ANY MODIFICATIONS,  
 ARE UNDERTAKEN ENTIRELY UPON THE USER'S RESPONSIBILITY AND AT THE USER'S OWN RISK.**

Please remember that all woodworking machinery is potentially dangerous, and all necessary precautions should be taken in its use. Particular care should be taken to provide proper eye and respiratory protection, and where guards are necessary, these should be fitted and used.

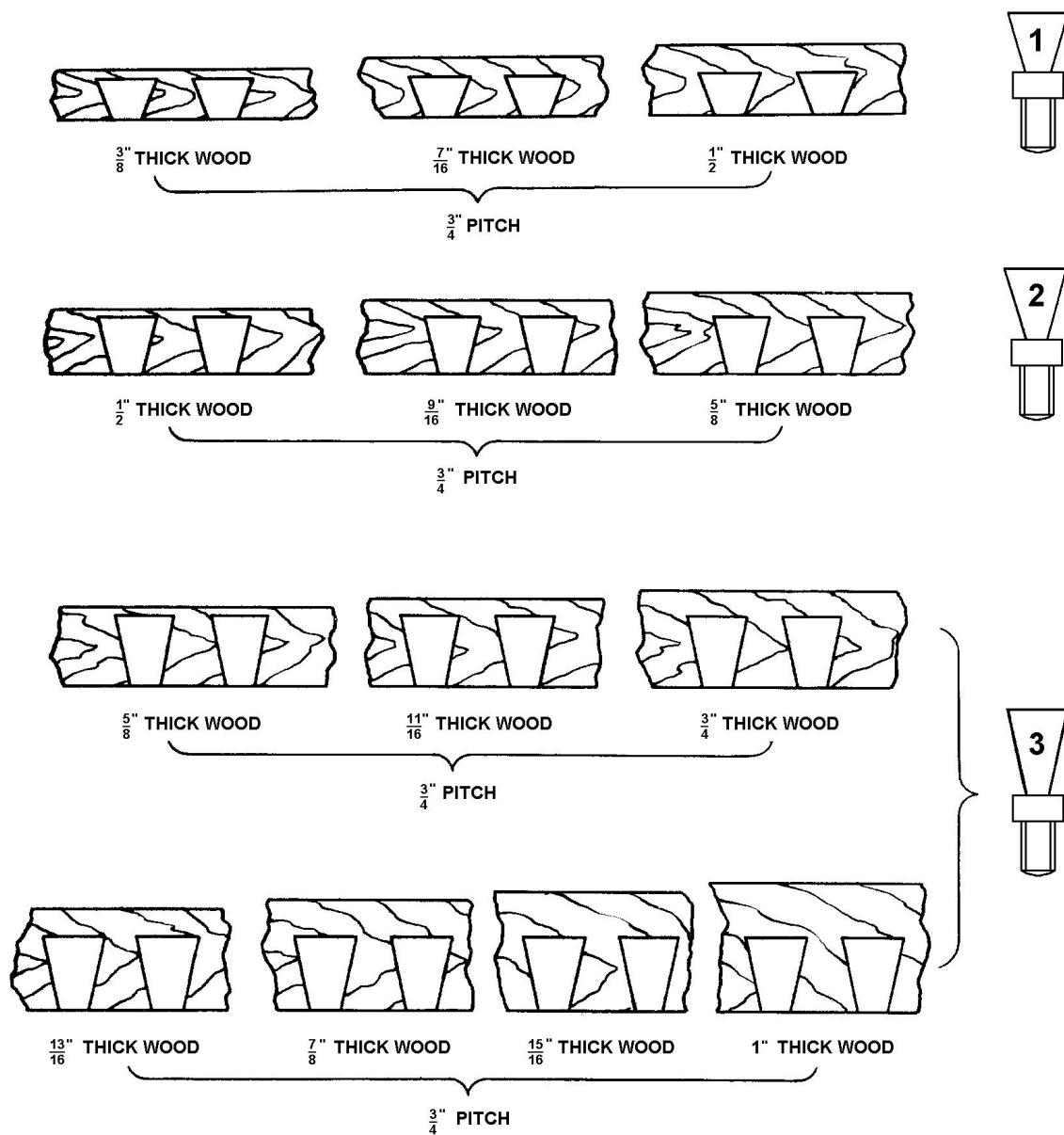

## Buying and Selling

---

**This is a topic that comes up regularly, and the question of price usually rears its head. I can't give any scale or idea of what you should be charging if you sell, or paying if you buy - there just aren't enough units on the market to set a pattern. On the one hand, I've seen a complete kit go for £30 on eBay (which I'd regard as indecently cheap) and on the other I've known someone keen to have one who paid £120+ without demur. Ultimately it depends on those two traditional factors - how quickly the vendor wishes to sell, and how badly the purchaser wishes to buy. The best advice I can offer is:**

1. If you're buying, don't buy an incomplete kit - especially if cutters and/or cutter-head are missing - spares are difficult if not impossible to find. The standard Arcoy Dovetailer consisted of a main comb/clamp assembly, plus a cutter holder and three cutters. Don't be tempted to buy an Arcoy that doesn't include at least this basic set.
2. If you're selling, don't let anyone talk you into selling the cutters and/or cutter-head on their own, unless, of course the main part of the machine is lost or broken - otherwise, what you're left with will be almost impossible to sell.
3. Don't sell your Arcoy for ready cash, thinking you'll buy another when you're flush - in all probability, you won't.
4. Although cutters and cutter-heads are the most sought-after spares, never throw away any part of a broken or decommissioned Arcoy Dovetailer - there might just be someone out there who needs just that part. I've had messages from users throughout the UK, Europe, the USA, Australia and New Zealand.
5. Given the average price of an Arcoy dovetailer on eBay, etc, the most economic way to buy spares, especially cutters, may well be to buy another complete kit.

**I'm afraid that, while I'm always happy to hear from anyone wishing to talk about the dovetailer and their own experience, requests for valuations or further buying or selling advice will not be answered.**

John Luby

This edition, March 2011