

Drawer Front Adjustment Fittings

Front Panel Adjustment Fittings

Consisting of: 1 insert, 15 mm dia.
1 adjusting element



- Pressed or glued into a 15 mm dia. hole in drawer front panel. (Minimum thickness of drawer front panel is 8 mm).
- Insert and adjusting element are placed according to drawing below.
- Drawer front panel at right fastened with 3.5 (#6) Hospa screws.
- Front panel can be adjusted ± 2 mm in the horizontal or vertical direction.
- Loosen the Hospa screws before adjusting.

Finish: plastic, white

Cat. No.	039.60.709
----------	------------

Packing: 1000 pcs.

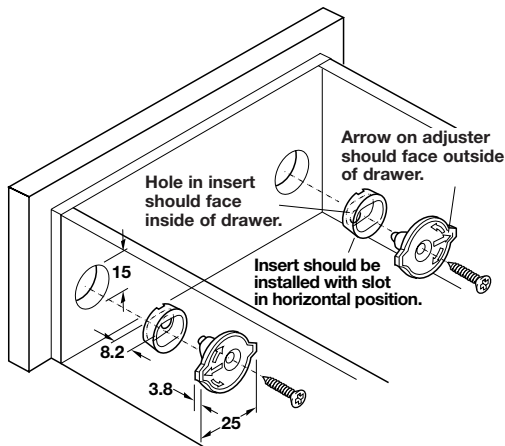
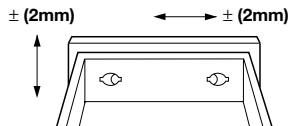
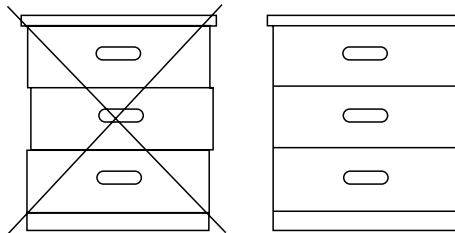

Drawer-Front Connector

Pressed in a 20 mm hole in drawer front.
Allows for ± 2 mm horizontal or vertical adjustment.



Finish: plastic, white

Cat. No. M4	430.90.704
8-32	430.90.713

Packing: 1000 pcs.

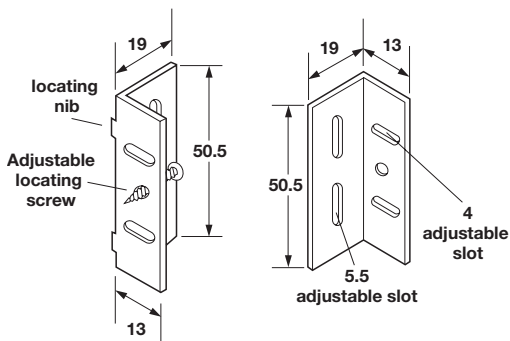
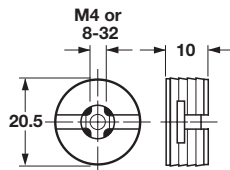

Finish: plastic, with self-adhesive cover cap

Color	Cat. No.	Packing
white	260.49.700	50 pcs.
beige	260.49.100	100 pcs.

Cat. No.	white without cover cap	260.49.701
	beige without cover cap	260.49.101



Articles Discontinued

Align locating nib with front edge of drawer and screw bracket onto the side of drawer box (Fig. 1). Place adjustable locating screw into the round single hole (Fig. 2). Close drawer completely and align drawer front. Line up drawer face to where you want it and hit with butt of hand to make impression with locating screw (Fig. 3). Pull drawer out, align locating screw impression and screw final three screws into drawer face (Fig. 4). Cover screws on bracket with the cover cap for the finishing touch.

Dimensions in mm
Inches are approximate

HÄFELE



Connectors and Shelf Supports

Installation of the drawer front connecting bracket.

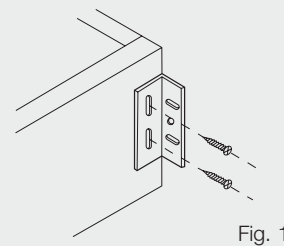

Fig. 1

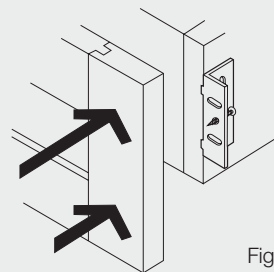

Fig. 2

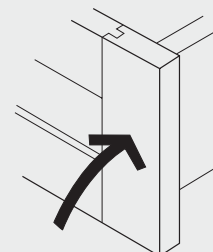

Fig. 3

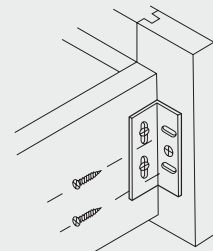

Fig. 4

Dimensional data not binding.
We reserve the right to alter specifications without notice.

TCH 04