

## build in one weekend

# WORKBENCH



All I wanted was a simple bench that was sturdy, had a large work surface, and didn't cost a lot. And I wanted to build it in a weekend. So Saturday morning I went to the local lumberyard and by Sunday night my basic bench was complete.

I used simple 2x4's for the base, and a solid-core door for the top—something you can usually find at building centers in their damaged goods section. Or, you can make the top out of two pieces of  $\frac{3}{4}$ " plywood.

The basic bench worked great, but by the next weekend I began thinking some drawers sure would be handy. So I added three drawers that are joined together with router-cut dovetails. I also added a sliding tray in one drawer to keep things organized.

Since I couldn't fit everything into the drawers, I added a shelf underneath, and finally, a woodworking vise on top. Of course, you can always alter the basic design of this plan to meet your particular needs.

**JOINERY.** The end frames of the bench are assembled with lap joints. But, instead of cutting lap joints in the traditional way, I built them up by laminating 2x4's together. The uprights are stacked (laminated) in a way to create "notches" for the crosspieces (braces), refer to the Exploded View.

This brought up the question of the best way to laminate the 2x4's together. If you have enough clamps, you can glue and clamp them together. Or, you can glue, and then nail them together. (Here I'd use finish nails.) Or, glue and screw them together.

There was another question about how to join the rails (horizontal pieces) to the legs. I chose a draw-bolt system that allows you to knock down the bench if you ever need to move it in the future.

**FINISH.** To protect the bench and keep glue from sticking to it, I finished the bench with two coats of General Finishes Two-Step oil/urethane finish.

# EXPLODED VIEW

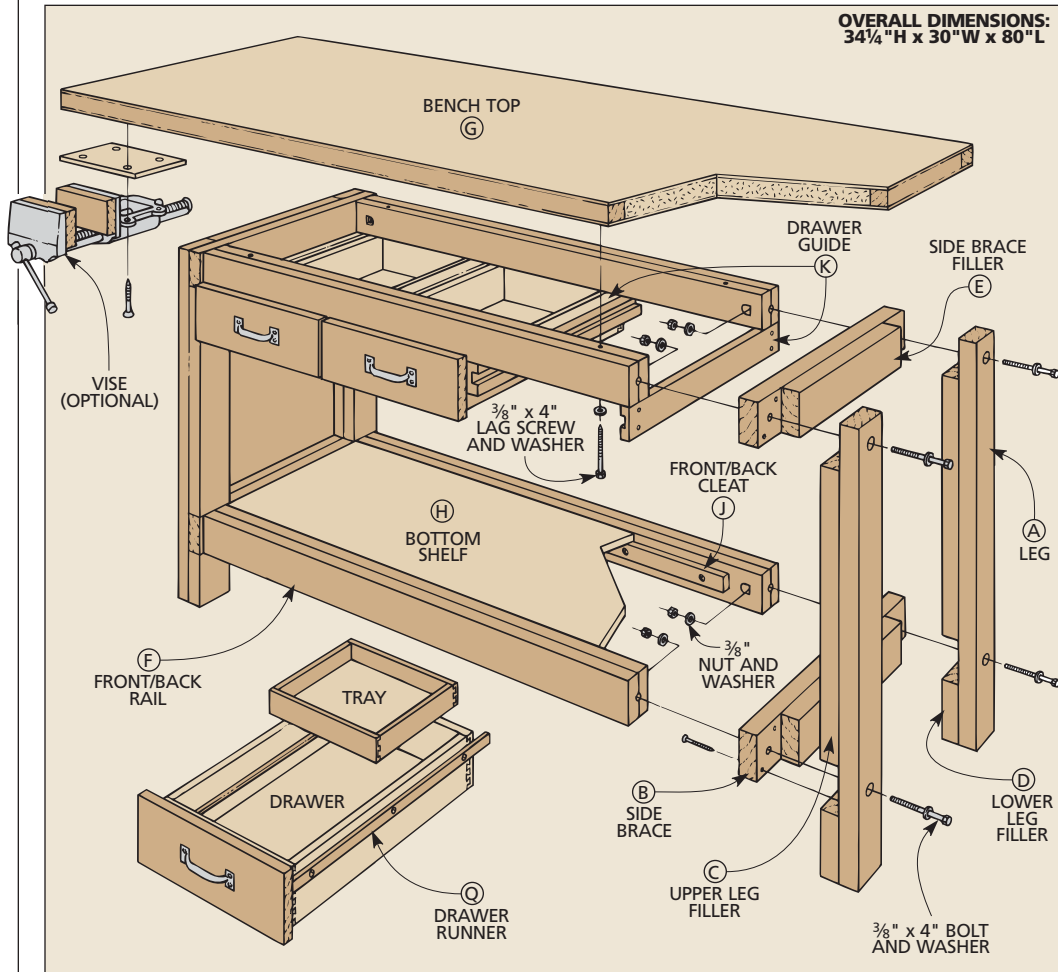

# SUPPLIES

## BASIC BENCH

- I (9) 2x4's, 96"-long
- I (1) 1 3/4" x 30" x 80" solid-core door (or laminate 2 sheets of 3/4" plywood together to get a 1 1/2"-thick top)
- I (1) piece 3/4" plywood, 24" x 48" (16 3/8" x 48" for shelf, use scrap for cleats)
- I (8) 3/8" x 4" hex bolts
- I (20) 3/8" washers
- I (8) 3/8" nuts
- I (4) 3/8" x 4" lag bolts
- I (16) #8 x 1 1/4" flathead wood screws
- I (100) #8 x 2 1/2" woodscrews or 8d finish nails

## DRAWERS

- I (4) 1x6's, 96"-long
- I (1) 3/4" x 5 1/2" - 96" (hardwood for drawer guide system)
- I (1) piece 1/4" plywood, 48" x 48" (for drawer and tray bottoms)
- I (18) #8 x 1" flathead woodscrews
- I (20) #8 x 1 1/4" flathead woodscrews
- I (8) #8 x 4" flathead woodscrews
- I (3) drawer pulls w/screws

## OPTIONAL

- I (1) woodworking vise

# MATERIALS

## BASIC BENCH

|                          |                        |
|--------------------------|------------------------|
| A Legs (4)               | 1 1/2 x 3 1/2 - 32 1/2 |
| B Side Braces (4)        | 1 1/2 x 3 1/2 - 23     |
| C Upper Leg Fillers (4)  | 1 1/2 x 3 1/2 - 21     |
| D Lower Leg Fillers (4)  | 1 1/2 x 3 1/2 - 4 1/2  |
| E Side Brace Fillers (4) | 1 1/2 x 3 1/2 - 16     |
| F Frnt./Back Rails (8)   | 1 1/2 x 3 1/2 - 48 3/8 |
| G Bench Top (1)          | 1 3/4 x 30 - 80        |
| H Bottom Shelf (1)       | 3/4 Ply. - 16 3/8 x 48 |
| I Side Cleats (2)        | 3/4 Ply. - 1 1/2 x 16  |
| J Frnt./Back Cleats (2)  | 3/4 Ply. - 1 1/2 x 42  |

## DRAWERS\*

|                         |                            |
|-------------------------|----------------------------|
| K Drawer Guides (6)     | 3/4 x 2 9/16 - 22 1/2      |
| L Drawer Stops (3)      | 3/4 x 1 - 14 1/2           |
| M Drawer Frt./Bcks. (6) | 3/4 x 4 3/8 - 14 1/2       |
| N Drawer Sides (6)      | 3/4 x 4 3/8 - 20 1/4       |
| O Drawer Bottoms (3)    | 1/4 Ply. - 13 1/2 x 20 1/8 |
| P False Fronts (3)      | 3/4 x 4 3/4 - 16           |
| Q Drawer Runners (6)    | 1/2 x 3/4 - 22 1/2         |
| R Tray Splines (2)      | 1/4 x 1/2 - 19 1/2         |
| S Tray Sides (2)        | 1/2 x 1 3/4 - 9 3/4        |
| T Tray Frnt./Backs (2)  | 1/2 x 1 3/4 - 12 7/8       |
| U Tray Bottom (1)       | 1/4 Ply. - 9 5/8 x 12 3/8  |

\*Material for three drawers and one tray

# CUTTING DIAGRAM

## BASIC BENCH

2 x 4 - 96" (ONE BOARD)



2 x 4 - 96" (FOUR BOARDS)



2 x 4 - 96" (FOUR BOARDS)



## DRAWERS

1 x 6 - 72" (TWO BOARDS)



1 x 6 - 96" (ONE BOARD)



1 x 6 - 96" (ONE BOARD)



3/4" (ACTUAL) x 5 1/2" - 96" (3.7 Bd. Ft.) HARDWOOD FOR GUIDES AND RUNNERS



**ALSO REQUIRES:** ONE PIECE OF 3/4" PLY-24" x 48", ONE PIECE OF 1/4" PLY-48" x 48" ONE SOLID-CORE DOOR OR TWO SHEETS OF 3/4" PLYWOOD FOR TOP

## END FRAMES

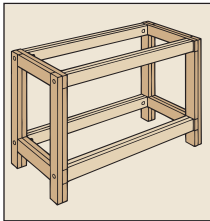

The first step in building the bench is to build the two end frames. To make each frame, begin by cutting two **legs (A)** to a length of  $32\frac{1}{2}$ ". (Note: This gives you an overall bench height of about  $34\frac{1}{4}$ " when the top is on.) The length of the legs can be varied to fit your height.

**BUILDING THE FRAMES.** With the legs cut to length, cut the two **side braces (B)** 23"

long, see Fig. 1. Lay two legs (A) side-by-side and position one side brace (B)  $4\frac{1}{2}$ " up from the bottom ends. Then place the other brace flush to the top of the legs, see Fig. 1.

Once the pieces are in place, lay out the screw locations, see Fig. 2. Then, drill and countersink  $\frac{3}{16}$ " shank holes in the side braces (B), see Fig. 2a. Now glue and screw the side braces to the legs using No. 8 x  $2\frac{1}{2}$ " woodscrews, see Fig. 2a.

**ATTACH THE FILLER PIECES.** To strengthen the end frames I added **upper (C)** and **lower leg fillers (D)**, and two **side brace fillers (E)**, see Fig. 3.

After I trimmed the filler pieces to fit, I clamped the pieces in position while I glued and screwed them in place, see Fig. 3.

**BOLT HOLES.** All that's left to complete the end frames is to drill and countersink the holes for the bolts that connect the rails, refer to Fig. 7. These holes are  $1\frac{3}{4}$ " down from the top edge of the side braces, and centered on the width of the legs, see Fig. 4.

Once the hole locations have been marked, counterbore 1"-dia. holes,  $\frac{3}{4}$ " deep on the *outside* face of the end frames. Then drill  $\frac{7}{16}$ "-dia. holes centered in the counterbores, see Fig. 4a.

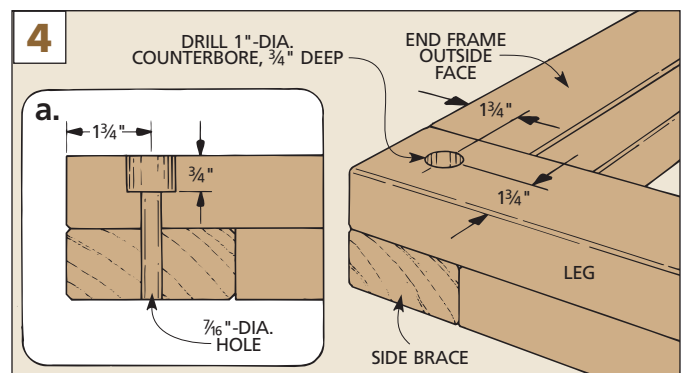
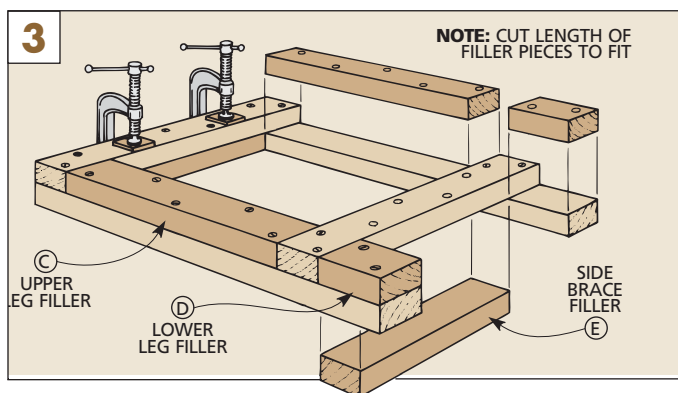
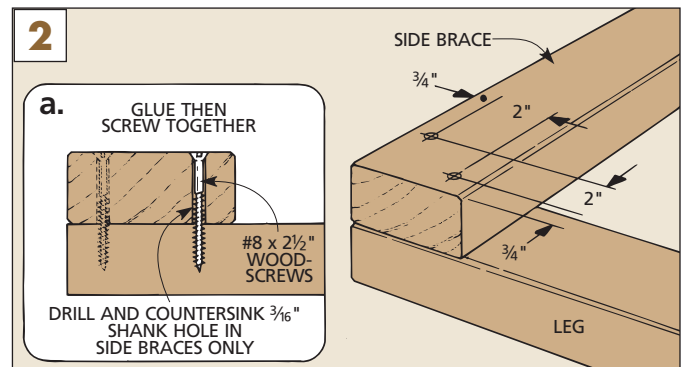
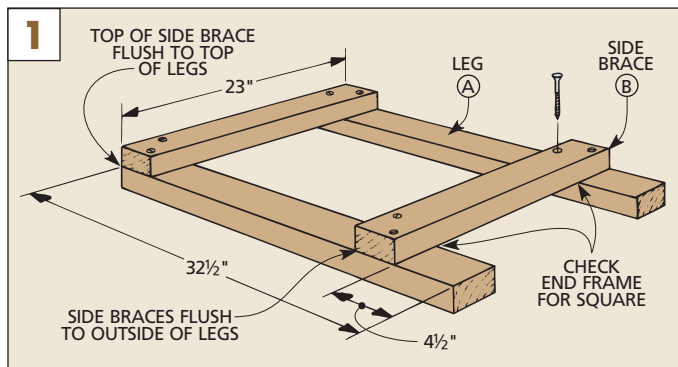

## RAILS

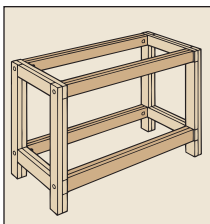

After the end frames are built, I made the four **rails (F)** that run across the front and back of the bench. Each rail is made from two 2x4's laminated together.

**BUILD THE RAILS.**

To make each rail, start by cutting two 2x4's to a rough length of 50". After the rail pieces are cut to rough length, glue them together to form a 3" x  $3\frac{1}{2}$ " rail blank, see Fig. 5.

Shop Note: Rather than using clamps, and then waiting for the glue to dry, I screwed the rails together with  $2\frac{1}{2}$ "-long screws. Be sure to drill shank holes and

countersink the holes before screwing the pieces together, see Fig. 5.

**TRIM TO LENGTH.** After gluing together all four rails, I trimmed them to a finished

length of  $48\frac{3}{8}$ ", see Fig. 5. (Note: The only reason for this particular length is so the Tool Cabinet shown in *Woodsmith* No. 50 would fit between the end frames.)

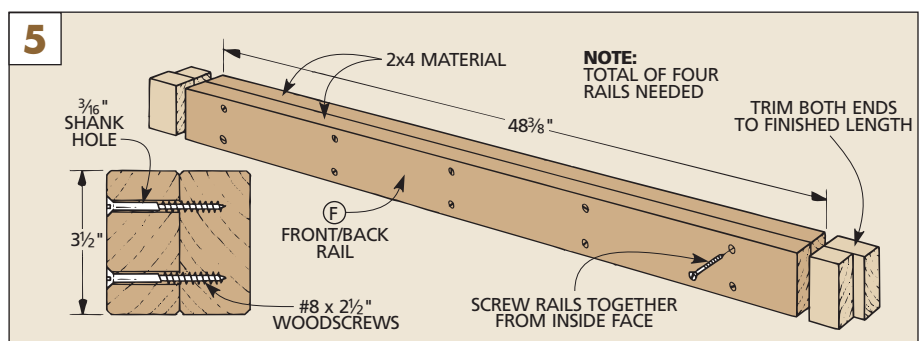

## RAIL CONNECTORS

The rails are connected to the end frames with a draw-bolt system. This system not only allows the joint to be tightened if it becomes loose, it's also easy to make and goes together quickly.

**POCKET HOLES.** The first step is to mark the location of the pocket holes on the rails. The holes are centered on the face of the rails and located  $1\frac{3}{4}$ " in from each end, see Fig. 6a. Now, drill a 1"-dia. hole, 2" deep at the marked location. Then, to provide a flat surface for the washer and nut to draw against, square up the edge of the hole nearest the end of the rail, see Fig. 6.

**END HOLES.** Once the pocket holes have been squared up, I drilled  $\frac{7}{16}$ "-dia. holes centered on the ends of the rails, see Fig. 6a. These holes are positioned in the center

of the flat side of the pocket hole.

**BOLT TOGETHER.** Now the rails can be bolted to the end frames. Just insert a  $\frac{3}{8}$ " x 4" hex head machine bolt with a washer. Push the bolt through the countersunk hole in the end frame and into the hole in the end of the rail, see Fig. 7.

Then slip a washer and nut in the pocket hole and tighten the bolt holding the nut with an open end wrench. (See the tip at right for a trick I used to start the nuts.) If the rails won't draw up tight against the end frames, you may want to use the undercutting technique shown in Shop Notes on page 7.

**Design Note:** To keep the pocket holes from showing, I positioned the rails so these holes faced in toward the center of the bench, see Exploded View on page 2.

## SHOP TIP

To help start the nut (in the pocket hole) on the end of the machine bolt, I attached the nut to a small scrap of wood with a piece of double-sided carpet tape.

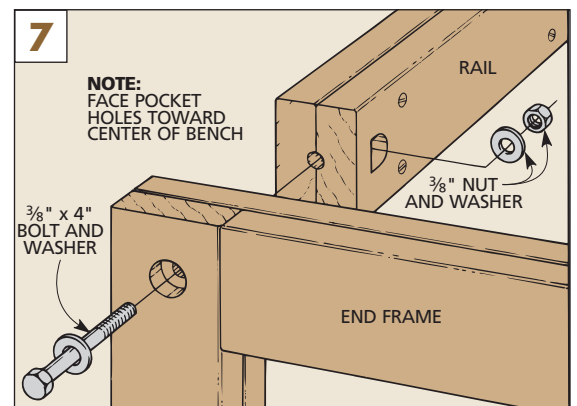
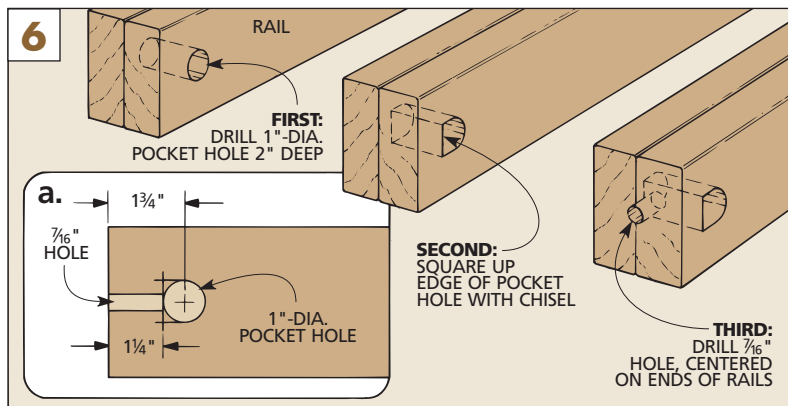
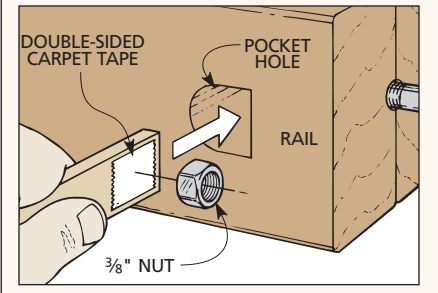

## TOP AND SHELF

After the base has been bolted together, all that's left is to attach the top (G) and bottom shelf (H). I used a  $1\frac{3}{4}$ "-thick solid-core door as a top. But you could laminate two pieces of  $\frac{3}{4}$ " plywood together instead.

### ATTACH THE TOP.

To attach the top (G), turn the top and the base upside down and center the base on the top. Then mark and drill the mounting holes on the bottom side of the top rails, see Fig. 8. Now attach the top with  $\frac{3}{8}$ " x 4" lag screws and washers.

**INSTALL SHELF.** Finally, cut a  $\frac{3}{4}$ " plywood shelf (H) to width to fit between the rails. (I used a 48"-long piece to fit between the end frames which are  $48\frac{3}{8}$ " apart.) Use some left over plywood to make  $1\frac{1}{2}$ "-wide shelf cleats (I, J). Then attach the shelf cleats  $\frac{3}{4}$ " down from the top inside edge of the bottom rails and side braces, see Fig. 9a. Note: Don't cover the pocket holes when attaching the cleats so you can get to the draw bolts.

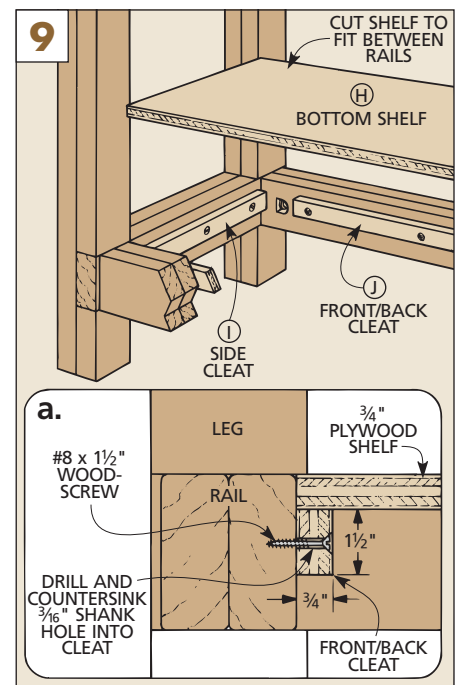
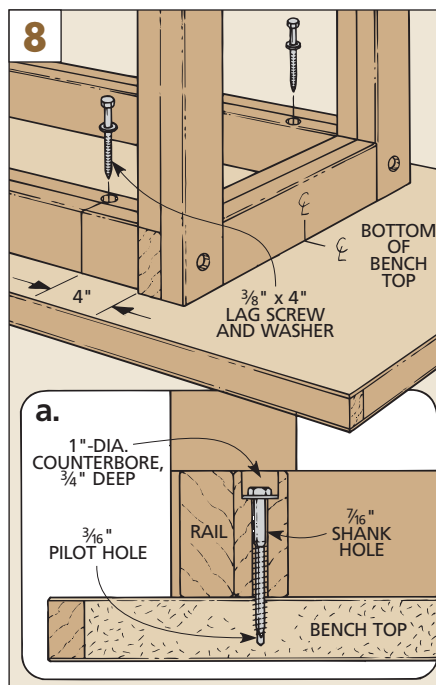

## DRAWER GUIDES

After the basic bench was built, I added a set of drawers. The first step here is to build and install the **drawer guides (K)**. For durability, I used hard maple to make the guides, but you could make them out of pine (same as the drawers).

**CUT GUIDES TO SIZE.** There are a total of six drawer guides made from  $\frac{3}{4}$ "-thick stock. However, the two center guides are laminated together, see Fig. 10. To make things easier, I glued up the two center guides to a rough width of  $2\frac{3}{4}$ ". Then I trimmed the center guides along with the two side guides to a finished width of  $2\frac{9}{16}$ " and cut them  $22\frac{1}{2}$ "-long, see Fig. 10.

**CUT THE GROOVES.** Once the guides are cut to size, grooves are cut to accept the drawer runners, see Fig. 10. I cut these  $\frac{1}{2}$ "-deep grooves with a  $\frac{3}{4}$ " dado blade.

To cut the grooves, first position the table saw fence  $\frac{7}{8}$ " from the blade. Then, to get the  $\frac{13}{16}$ "-wide groove centered on the guides, I made two passes, turning the pieces end-for-end after each pass.

**MOUNT THE GUIDES.** After the grooves have been cut, drill and countersink shank holes at the locations shown in Fig. 10. Then position the side guides so they're flush against the top front rail (F) and screw them to the legs (A) with No. 8 x  $1\frac{1}{4}$ " flathead woodscrews, see Fig. 11.

With the side guides in place, position the center guides so the three drawer openings are equal, see Fig. 11. Once they're in place, screw the center guides to the top rails with No. 8 x 4" screws, see Fig. 12.

**DRAWER STOPS.** Finally, I cut **drawer stops (L)** to stop the back of the drawer, see Fig. 13. After building the drawers, screw the stops in position so the back of the drawers hit the stops before the drawer's false front hits the end of the drawer guides.

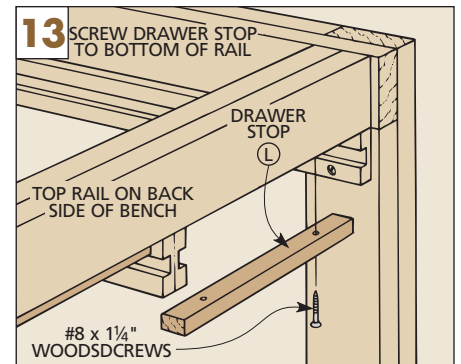
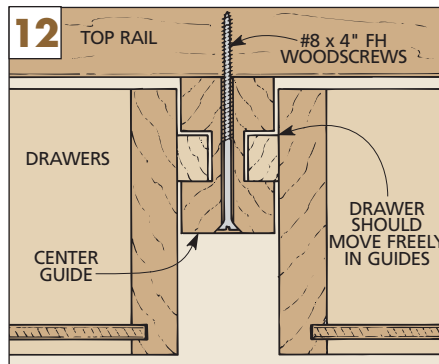
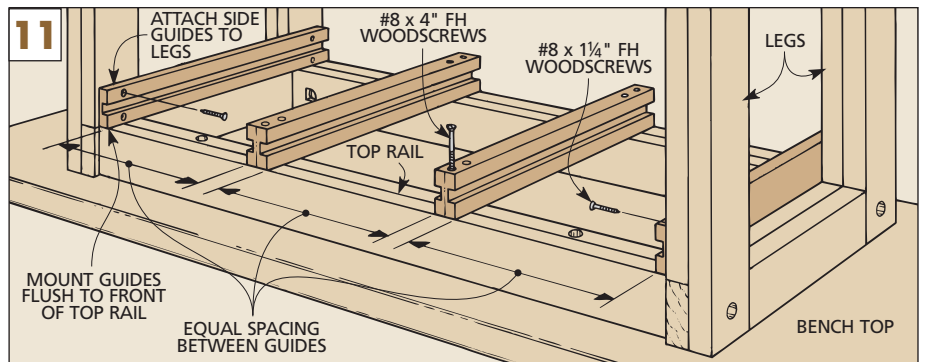
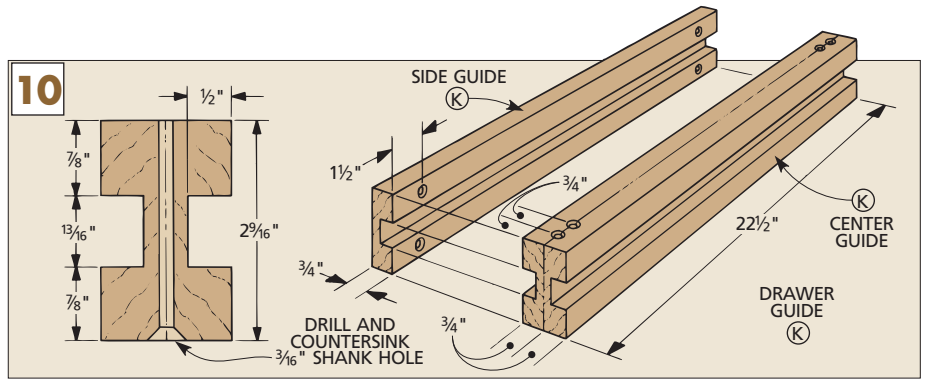

## ALTERNATE DRAWER JOINT

As an alternative to using a dovetail joint for the drawers (shown on opposite page), you could use a dado/rabbet corner joint. If you do, the drawer fronts/back (M) are cut 1" shorter ( $13\frac{1}{2}$ "-long), and the sides (N) are cut 1" longer ( $21\frac{1}{4}$ "-long).

This joint is made by cutting a  $\frac{1}{4}$ " x  $\frac{1}{4}$ " dado on the drawer sides (N), located  $\frac{3}{4}$ " in from each end, see Fig. 2. Then, cut the mating  $\frac{1}{4}$ " x  $\frac{1}{4}$ " tongue on both ends of the drawer fronts and backs, see Fig. 2.

After cutting the joints, cut the grooves for the drawer bottoms. Also cut grooves in two drawer sides for the tray splines.

Complete the drawers by cutting the bottoms (O) to fit. Then glue up the drawers, tacking the corners together, see Fig. 1.

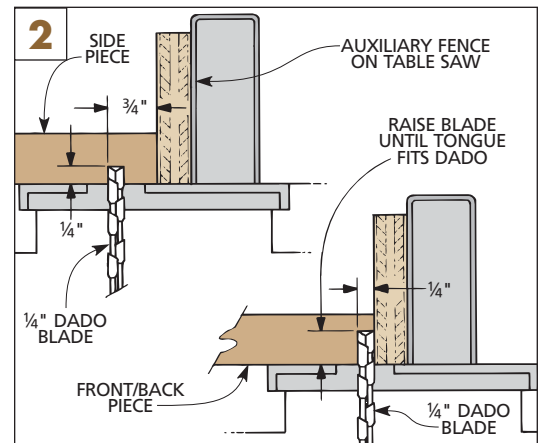
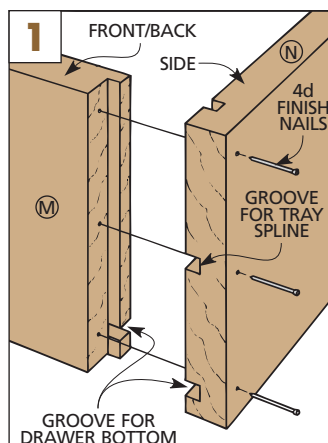

## DRAWERS



When the drawer guides are in place, the drawers can be built to fit between the guides. Since these drawers will be subjected to a lot of weight, I built them with dovetail joints, using a router and a dovetail jig. (For an alternate joint, see the box on the previous page.)

To build the drawers, start by cutting the **fronts/back** (M) to length,  $\frac{1}{8}$ " less than the distance between the drawer guides and to a width of  $4\frac{3}{8}$ ", see Fig. 14. Then cut the **sides** (N) to the same width and  $20\frac{1}{4}$ " long.

After the pieces have been cut to size, rout the dovetail joints on the ends of the pieces.

**BOTTOM GROOVE.** Before assembling the drawer, cut a  $\frac{1}{4}$ "-deep groove for the plywood **bottom** (O), see Fig. 15. The width of the groove is determined by the thickness of the plywood. (In our case this was  $\frac{1}{4}$ ".)

**TRAY GROOVE.** To provide additional storage, I added a tray to one of the drawers, refer to Fig. 17. To make a ledge for the tray to slide on, cut a groove 2" down from the top edge of the drawer sides, see Fig. 15.

After the tray groove is cut, assemble the drawers. Then cut the  $\frac{1}{4}$ " x  $\frac{1}{2}$ " **tray splines** (R) to fit in the grooves and glue them in place, see Fig. 14.

**FALSE FRONTS.** The next step is to cut and attach the **false fronts** (P). Once the fronts are cut, drill and countersink four mounting holes, see Fig. 15. Then position the fronts flush to the bottom of the drawer and centered on the width, and screw them to the drawers, see Fig. 16.

**RUNNERS.** All that's left to complete the drawers is to cut the  $22\frac{1}{2}$ "-long hardwood **drawer runners** (Q) and mount them so they slide in the drawer guides, see Fig. 16.

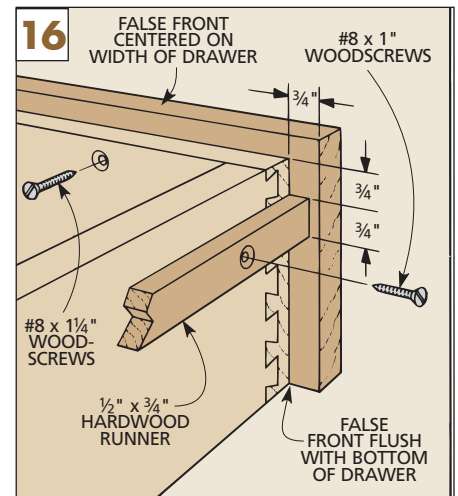
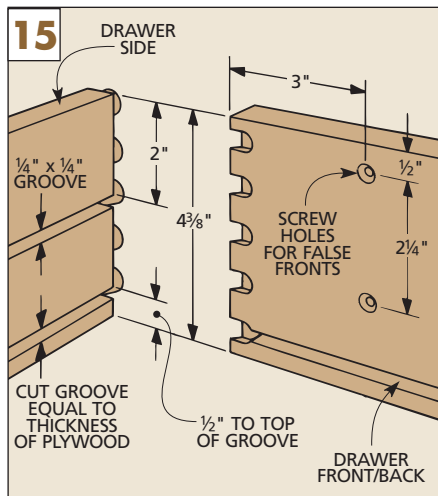
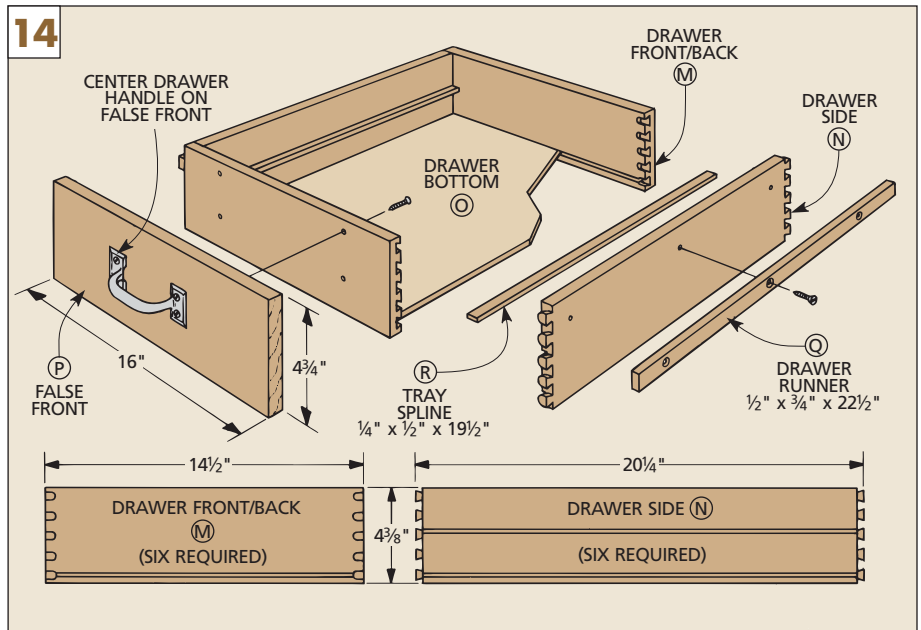

## TRAY

It's always aggravating when small tools get lost in the bottom of a large drawer. To keep this from happening, I built a shallow sliding tray for one of the drawers.

**THE SIDES.** The first step in building the tray is to cut the  $\frac{1}{2}$ "-thick,  $1\frac{3}{4}$ "-wide tray sides (S) to length, see Fig. 17. Then cut the **front and back** (T) pieces  $\frac{1}{8}$ " smaller than the inside of the drawer. On our tray this was  $12\frac{7}{8}$ ", see Fig. 17.

Once the tray pieces are cut to length, the ends can be dovetailed together. (If you use the alternate joint shown on the previous page, the length of the pieces will be different.) Also cut grooves for the plywood bottom (see Fig. 17a.) and assemble the tray.

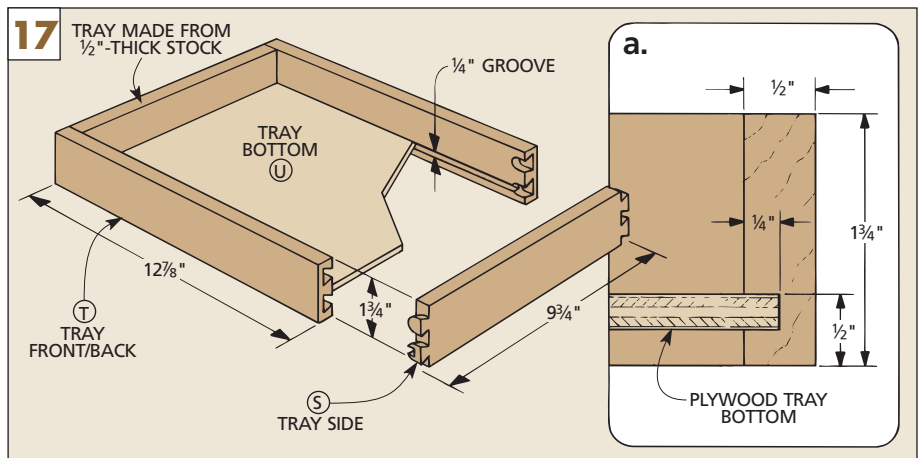

# Shop Notes

## UNDERCUTTING

Sometimes it's difficult to get a tight joint line when you butt one piece into another. (Like attaching the rails to the legs on the Workbench.) The problem is both surfaces need to be perfectly flat for the joint to pull completely together.

**UNDERCUTTING.** To avoid problems, I use a technique called undercutting. This is simply cutting out a recess on the end of the rails until a small shoulder remains around the perimeter. Since only the should-

er touches the adjoining piece, it's much easier to pull the joint tight, see Fig. 1.

**UNDERCUTTING THE ENDS.** To undercut the rails on the Workbench, I laid out a 1/4"-wide border around the perimeter of the ends of the rails, see Fig. 2. Then I chopped straight down on this border line with a chisel to score the line 1/16"-deep.

**CHOP OUT WASTE.** Once the border line is defined, the waste can be chiseled away. To do this, hold the chisel with the bevel facing

against the end of the rail. This keeps the chisel from digging too deeply, see Fig. 2.

To keep the shoulder from breaking off, start the chisel at the border line, paring away the end grain as you work toward the center of the recess, see Fig. 2a. After the end of the rail has been undercut, attach the rail to the leg. As you tighten the draw-bolt, the joint should pull together without gaps.

