

Ductwork Design and Installation Guide

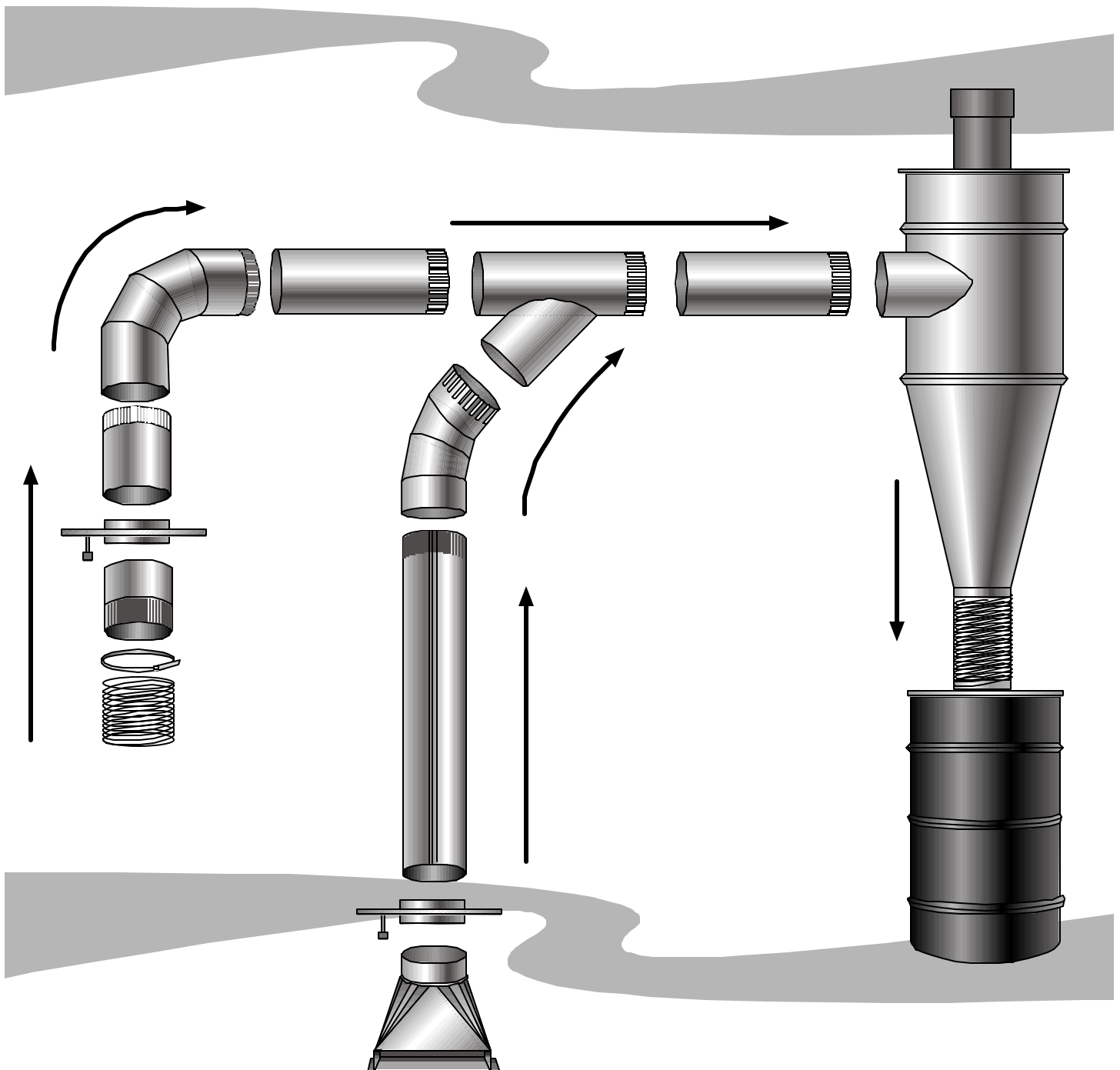

I. A Practical Guide for Ducting

General Guidelines for an Efficient Duct System

Big molders or machines that generate huge quantities of solid material generally need 22 - 18 gauge pipe and fittings for industrial survivability and safety. Small custom shops do well with 26 - 22 gauge pipe and fittings. Thinner gauges (such as HVAC pipe) can collapse under fan pressure or dent too easily.

- ▶ Ducting causes friction or drag which reduces fan performance. Shorter, more direct pipe runs are best and will deliver more air volume to woodworking machine.
- ▶ Elbows and turns should be kept to minimum. The fewer the turns the better and the shorter the degree angle of turn the better.
For example: A 90 degree elbow is equivalent to 6 - 8 feet straight pipe friction loss. A 45 degree elbow is equivalent to 3 - 4 feet straight pipe friction loss. (See Fig.1) **To minimize friction loss use large radius elbows, with center line radius at least 1.5 times diameter.**
- ▶ Flex hose connections to machines can be the simplest and easiest way to connect machines to the metal duct (see Fig. 2). Flex hose creates more air resistance than metal pipe. Use short lengths of flex hose for connecting to machines. **Use wire wrapped helix flex hose for static grounding, bare ends so they contact metal pipe.**
- ▶ Blast gates should be used at every machine to control air flow. Pre-drill blast gate and sheet metal screw or pop rivet to metal ductwork. Seal with silicone. Thumbscrew should face opposite the direction of airflow or towards the woodworking machine.
- ▶ Use 45 degree wye branches, not 90 degree tee branches. A 45 degree wye with a 90 degree elbow adjusted to 45 degrees will create a gentle sweep that can be used as a vertical drop or a right or left turn off of the main duct line (see Fig.3).
- ▶ Use 3 - 4 pop rivets or sheet metal screws (will not collect dust) to join pipe and fittings together. Recommended size: #8 1/2" sheet metal screws or 5/32" aluminum rivets.
- ▶ Seal all ducting with silicone or duct tape or metal tape. Silicone sealant is the most permanent. We recommend putting silicone on the outside of connection so duct work can be disassembled if needed. Small cracks create significant air loss. Well sealed ductwork will insure you have maximum air available at your woodworking machine where it is needed. (All joints on adjustable elbows should be sealed after installation.)
Seam that runs length of straight pipe does not need sealing.

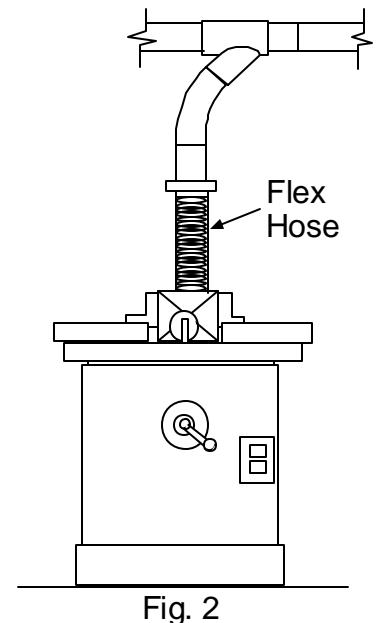
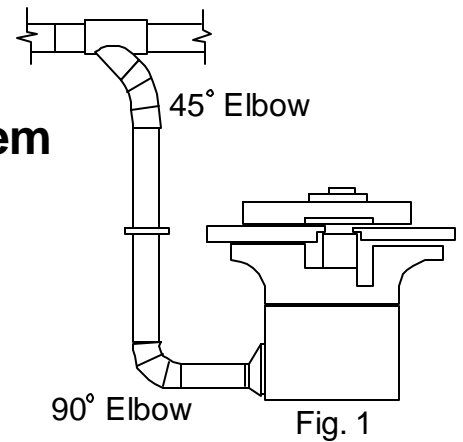
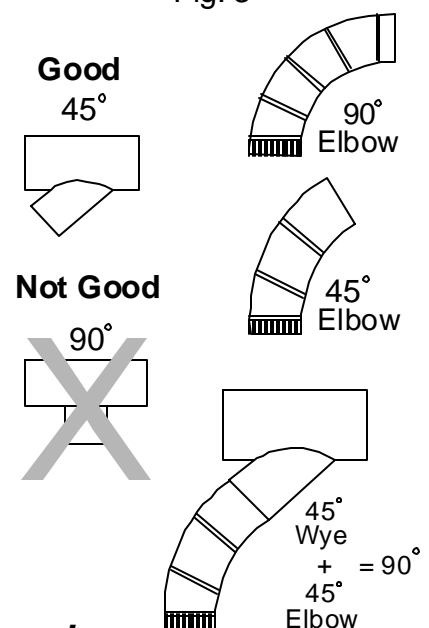

Fig. 3



Caution: Wear Gloves! Sheet metal fittings can have sharp edges.

Metal pipe is safer than PVC.

Scientists, engineers, and industry experts who work in insurance, human safety, woodworking, and equipment manufacturing consistently agree that plastic pipe should not be used in material (wood waste) conveying. In the National Fire Protection Association's 2002 edition, Chap.8 / 8.2.2.2.1.2 states about wood waste conveyance, "Nonconductive ducts such as PVC pipes shall not be permitted."

Some of the reasoning is as follows:

- ▶ Static sparks arcing internally or externally can ignite combustible mixtures inside or outside the pipe, not limited to wood dust mixtures.
- ▶ Static sparks arcing from the pipe can jolt, injure or startle personnel working on dangerous equipment.
- ▶ Limited choices of pipe size. Fittings are not designed for pneumatic conveying, compromising efficiency and good design.



The Importance of Pipe Sizing

4" PVC Pipe vs. 5" Metal Pipe

Metal ducting should be used for woodworking. Straight PVC or ungrounded plastic creates static charges which can ignite a fine wood dust mixture (cellulose mixtures can be explosive). Plastic is also more restrictive.

Oneida chooses to use metal pipe, large radius elbows and 45 degree wye branches as do all dust collection experts in the industry. Metal pipe is used because it provides substantially better performance and proper fittings are readily available. Good duct design using air handling ductwork and fittings deliver substantially more air out at the tool where it is needed.

Many people are using 4" PVC simply because it is easy and it does work. If one didn't know any better, they might think that their performance was as good as could be expected, but, you can expect more than a 50% gain in performance just by running the proper diameter pipe and the right fittings. 4" pipe can move 365 cfm which is sufficient for small tools but is not enough air to clean heavy dust producing machines such as table saws and planers effectively.

5" pipe is by far the best choice for the small wood shop and keeps your ducts clear with a wood dust conveying range of 425 to 650 cfm. One might ask, "If 5 inch is better than 4 inch, then is 6 inch better than 5 inch?" Six inch pipe with the amount of airflow that a small dust collector can provide (600 - 700 cfm) is generally too large in cross section, especially when the diameter is necked down at the tool. The result will be low airspeeds in the ductwork and dust accumulation (fallout) in the duct. This creates a fire hazard and a possible clogging problem. For small shops, 5" ductwork seems to be the "sweet spot", providing the best compromise between airflow and efficiency.

See the chart on following page for recommended CFM and pipe diameters for woodworking machines

General CFM Requirements for Woodworking Machines

Machines	Air Required (Cfm) for Maximum Cleaning	Duct Branch Diameters & Appropriate Hood Port Size
Drum Sanders* (Dual drum 24" or larger)	650 - 800 Cfm	6" Dia.
Planer* (18 - 20")	700 - 800 Cfm	6" Dia.
Band Saw (18 - 20")	550 Cfm	5" Dia.
Belt / Disc Sanders - 8" Wide Belt	450 - 650 Cfm	5" Dia.
Drum Sanders (Single Drum 12 - 24")	500 - 600 Cfm	5" Dia.
Jointer (8 - 12")	450 - 550 Cfm	5" Dia.
Lathe* (Large)	650 Cfm	5" Dia.
Lathe (Small)	450 - 550 Cfm	4" Dia.
Planer (10 - 15")	500 - 600 Cfm	5" Dia.
Radial Arm Saw	400 - 550 Cfm	4 or 5" Dia.
Shapers 1 1/2 to 3 Hp	450 - 550 Cfm	5" Dia.
Table Saw (10 - 16")	400 - 600 Cfm	5" Dia.
Band Saw (12" - 16")	300 - 450 Cfm	4" Dia.
Drill Press	300 - 450 Cfm	4" Dia.
Hand Sanders	300 - 450 Cfm	4" Dia.
Jointer (6 - 8")	300 - 450 Cfm	4 or 5" Dia.
Scroll Saw	300 - 450 Cfm	4" Dia.
Shaper 3/4 Hp	300 - 450 Cfm	4" Dia.

* These are very high air requirement machines, they should be located very close to the collector and have 6" diameter drops direct from the main trunk line. Do NOT locate these machines farther than 20' away from the collector for maximum dust removal.

Note: Some machines have built in ports with fixed castings. If your machine has a smaller port diameter, run the recommended pipe size, then reduce at the machine.

Oneida Air Systems, Inc. provides a ductwork design service to customers. OAS will design the correct duct size and layout, ensuring a configuration that will provide the correct air flow to effectively collect the wood waste at the source. Effective collection of wood dust at the point of generation prevents airborne dust which can cause an unhealthy and unsafe working environment.

If you have questions about ductwork sizing or layout or wish to take advantage of our ductwork design service, please call us at 1.800.732.4065 M - Th. 7:30am - 6:00pm EST. Fri. 7:30am - 5:00pm EST.

Designing Vertical Drops

Combining machines on one vertical drop is sometimes necessary to save space and eliminate the need for multiple drops. A vertical drop with multiple wye branches can be used when operating one woodworking machine at a time (see diagram). Blast Gates must be used to regulate air flow to individual machines. Floor sweeps or elbows can be used to secure and anchor the vertical drop to the floor (see diagram).

Note: 5" or 6" diameter drops should be used for floor sweeps. Oneida Air Systems offers inexpensive floor sweeps 2" high, 12" long, to a 5" or 6" round at the top. A blast gate placed above the hood will regulate air flow. (Part: Floor Sweep 5 no door, DSN050000, DSN060000) Floor Sweeps with doors do not require Blast Gates.

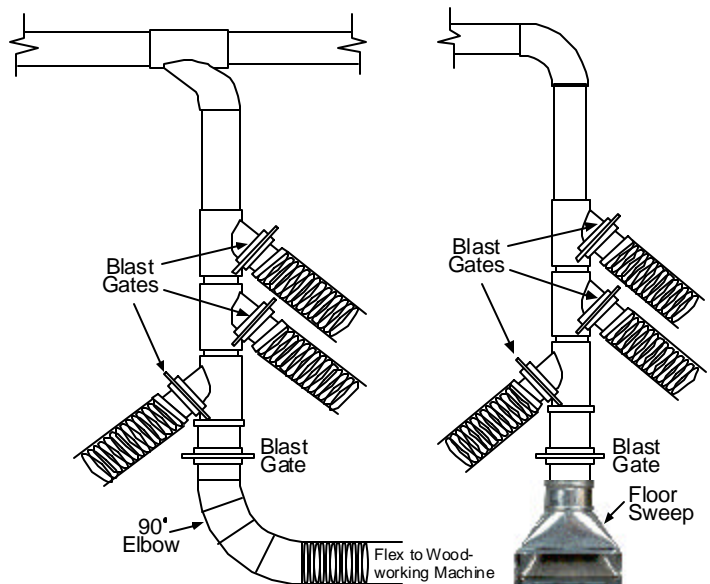

Locating the Collector

- ▶ Centrally locate the collector if possible. Keep ductwork to a minimum and you will have more air available at your machine.
- ▶ Locate your highest air requirement machines (table saws, planers, jointers, and shapers) closest to the collector.
- ▶ Long duct runs (more than 30 ft.) will create more resistance resulting in lower air flows.

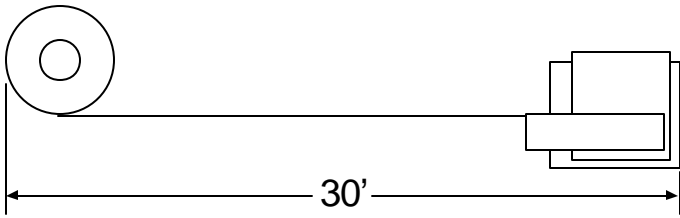

- ▶ Eliminate bends and turns as much as possible.

Note: Compare runs of ductwork in the illustrations to the right.



Good

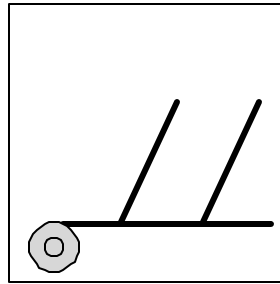

Good

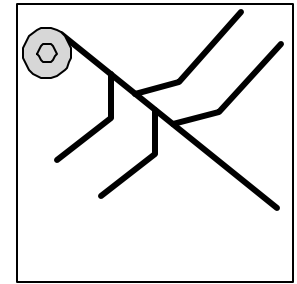

Good

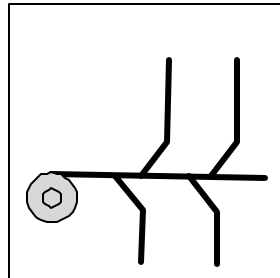

Good

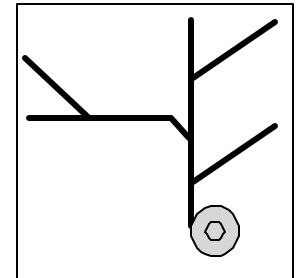

Poor

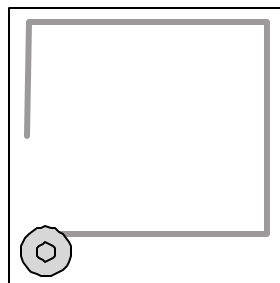

Poor

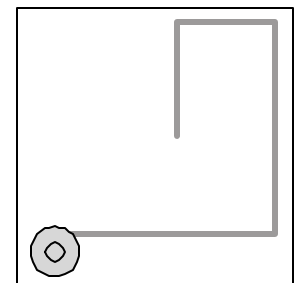

Mounting the Collector

If possible, adjust height of unit so that the main trunk line can be run straight into collector inlet.

- ▶ Flex coupling length can be adjusted for optimum mounting height.
- ▶ Avoid sharp elbows or double elbows near the inlet. (see illustrations)
 - If elbows are required, try to run 1 or 2 ft. of straight pipe at the collector inlet, to allow a smoother, less turbulent flow of air into the cyclone.
- ▶ Motor can be positioned between ceiling joists to obtain increased height. Leave at least 1" between motor and ceiling.

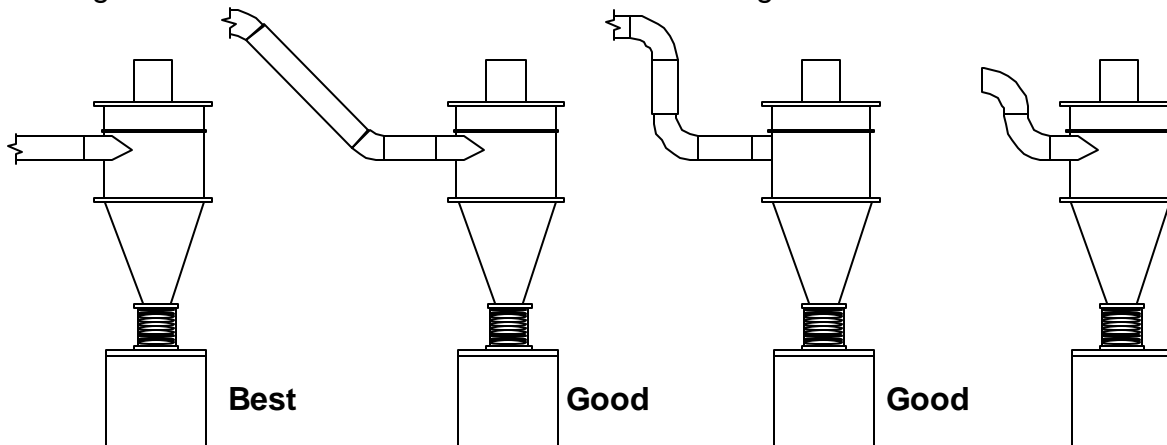
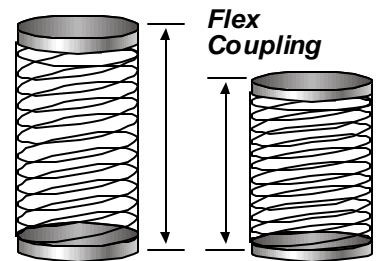

** Two elbows back to back create a system effect with higher pressure drop.*

Working with Oneida Air Systems Snap Lock Ductwork

1. Lay out all of the pieces - Fig. 1
Check to see if you received all of the parts that you ordered.

2. Snap Lock Pipe -

A. Measure and cut pipe with tin snips or power saw before snapping the seam together. Fig. 2

B. Start at the crimped end and snap the two sides together. Hold together with one hand and move down the pipe as the seam snaps in. When you get halfway, it should snap fully closed. Fig. 3 & 4

C. Crimped ends face Dust Collector.

D. Join pipe to fittings using 3 - 4 sheet metal screws or pop rivets. Fig. 5

E. Use hangers to support the pipe every 3 to 4'. Fig. 6

F. Seal all joints and seams with silicone sealant or duct tape including all seams on elbows.

3. Blast Gate Assembly -

The blast gates can have the thumb screws located on either side. The thumb screw should be used to tighten down the plate toward the Dust Collector. The plate should press against the blast gate in the direction of the air flow. Use Blast Gate Adaptors. (Straight pipe, 4" long, crimped on one end to accept Flex Hose.) Blast Gate Adaptors can be pop riveted or sheet metal screwed to the Blast Gate to give support to Flex Hose connections. Fig. 7

4. Flex Hose -

Short pieces of flex hose 5' and under do not have to be grounded. You can use the internal wire in the flex hose as a grounding wire if you want.

Flex Hose can be used for the final run between the pipe and woodworking machines. Attach Flex to pipe and machine with a quick release Band Clamp. Fig. 8



Fig. 1

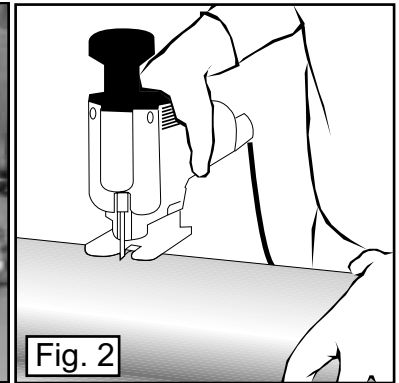

Fig. 2

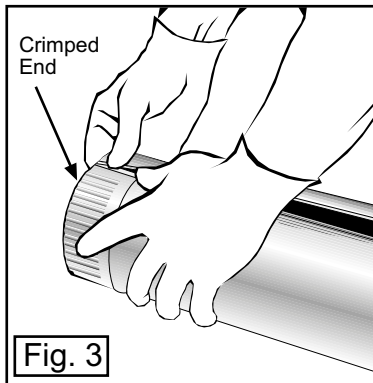

Fig. 3

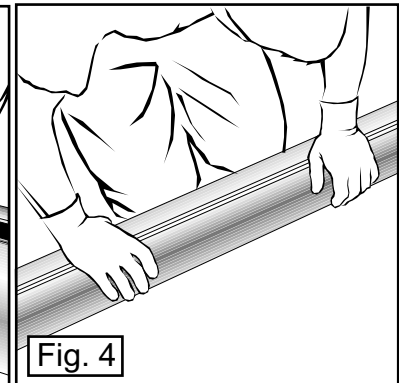

Fig. 4

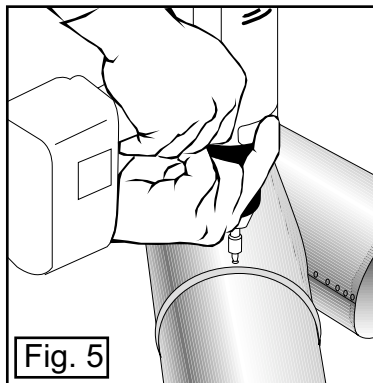

Fig. 5

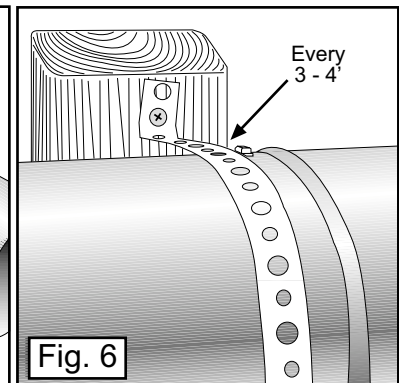

Fig. 6

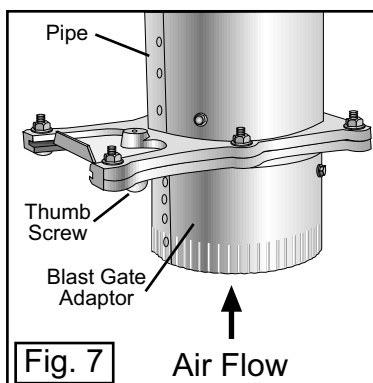

Fig. 7

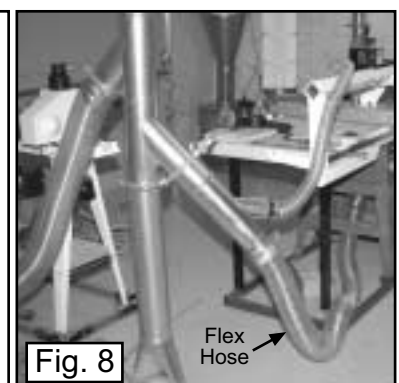

Fig. 8

CAUTION: Sheet metal fittings can have SHARP edges. We recommend that you wear protective gloves.

Working with Oneida Air Systems Snap Lock Ductwork

5. Adjustable Elbows -

To rotate sections for a 45 degree elbow, you may need another person. To loosen the adjustable elbows, gently tap the ends on a flat surface. This loosens up the seams and the sections should rotate easier. To make a 45 degree elbow, have someone hold the bottom section still, then rotate top section 1/4 turn (90 degrees). Then alternate the rotation with each section until you get a 45 or an angle that you want.

A helpful way to do this is to draw a line down the center back of the elbow with a marker then using the above technique, turn each section so that the centerline is 90 degrees away from its original position. (see Fig. 1)

OAS Ductwork Catalog lists the standard sizes and gauges. Heavy gauge one piece elbows do not come crimped, you must use an adapter to join spiral pipe segments and fittings. One piece Elbows and Spiral Pipe are also available.

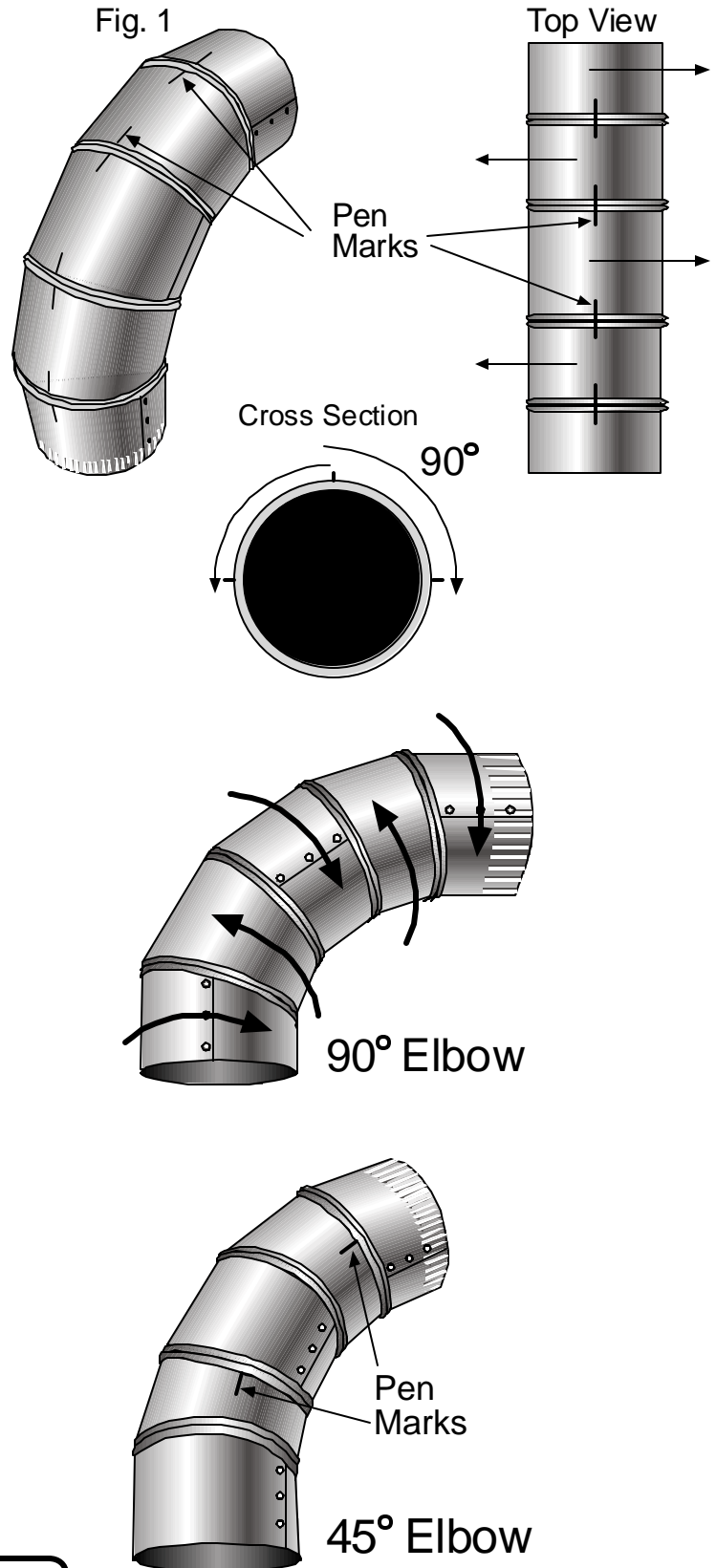

CAUTION: Sheet metal fittings can have SHARP edges. We recommend that you wear protective gloves.

II. Hood Design

Hood design is essential to good dust collection. If your machines are not equipped with compatible dust ports, hoods can be retrofitted as shown below.

Common Compatibility Problems

Small dust ports: Dust ports are often designed for shop vacs, not dust collectors. Dust collectors use high volumes of air to convey particulate over long distances, vacs use high suction and low air flow.

No dust ports: Older woodworking machines often do not have dust port connections. The following hood diagrams and text offer possible solutions.

Table Saws

Cabinet, Unisaw, & Contractor Table Saws

A hood can be retrofitted over the opening of an existing dust chute by sheet metal screwing the hood to the metal cabinet or sides of the dust chute. A hood or flat plate with a round collar can be sheet metal screwed over a square or hole cut into the cabinet of the table saws with no dust ports.

With open space and cracks well-sealed, there will be more internal air and suction directly on the saw blade. Enclosed cabinets must be sealed to eliminate loss of air through cracks or openings. Foam or sponges can be used to fill large air spaces in the cabinet. Air blocks made of thin plywood or metal can be sheet metal screwed to the inside of the cabinet around dust chutes. Magnetic sheets (magnetic sign material) can be used on the exterior to cover vents or slots that need to remain open for table saw adjustments.

For contractor saws the opening around the motor must be enclosed with plywood or sheet metal.

Standard hoods can be generic square to round adapters (vertical and horizontal dimensions can vary) or a flat plate with a round collar for connecting pipe or flex hose. (see illustration #1)

Note: Do not seal off all openings, a cross-sectional area equivalent to the pipe area must be open to allow sufficient air flow.

Open Table Saw, Rip Saw, or some Miter Saws

Rectangular hoods can be fitted up under the saw blade. (see illustration #2)

Miter Saw - Rear Collection

Rectangular to round hoods can be mounted behind the blade. Plywood or metal extension wings can be used to extend coverage around the blade. Flex connections on miter saws are used so that the hoods can be moved when the angle of the blade is changed. (See illustration #3)

Illustration #1

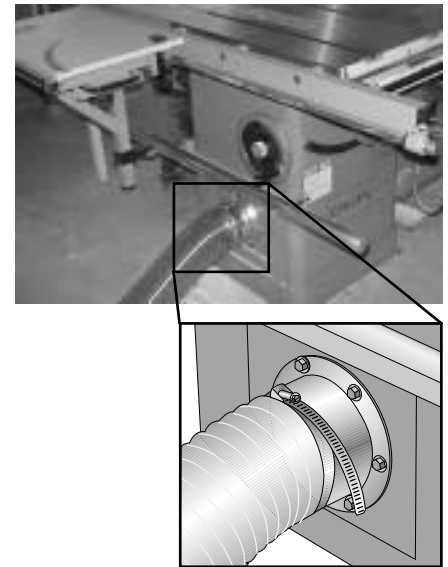

Illustration #2

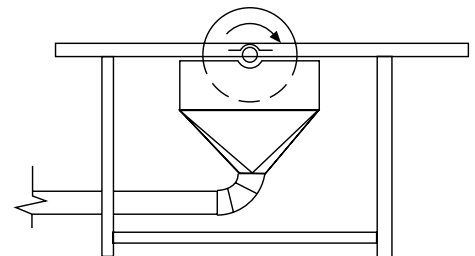

Illustration #3



Radial Arm Saw / Miter Saw

Rectangular to round hoods can be mounted behind the blade, wye branches such as 5" x 4" x 3" can be used to split the main collector line between the hood and the blade guard. Use 4" to the hood and 3" or 2" to the blade guard. (see illustration #4)

Jointer

Cabinet & Chute Types

Follow recommendations for enclosed table saw. Generic hood design (vertical and horizontal) can vary.

Open Cabinet

Ideally, hoods can be fitted under blade. (see ill. 5)

Generic hoods such as 10" x 2" to 5" dia. can be used. (see ill.6)

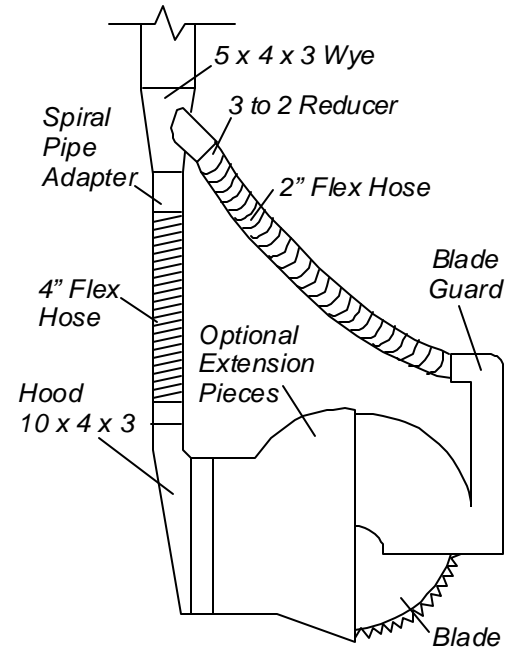

Illustration #4

Illustration #5

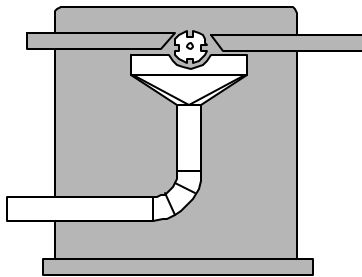
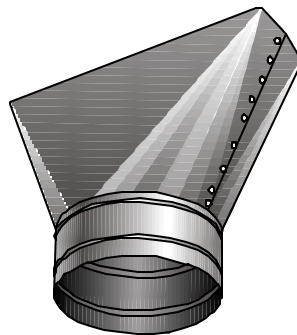

Illustration #6



Band Saws with Small or No Front Dust Port

Band Saw's original dust port was made for a shop vac connection. To modify for a retrofit dust port, block original port, cut the proper diameter hole for size of band saw in the case and attach collar with sheet metal screws. Attach elbow to collar, then attach Flex Hose to Elbow. (see ill. 7)

Band Saws with front and back ports can use the same hood design as above for the front port. Split the main collector branch line for front and back pickup (see ill. 8)

If port cannot be modified, use an increaser directly on the existing dust port. For example 2 1/4" - 4" Increaser / Reducer.

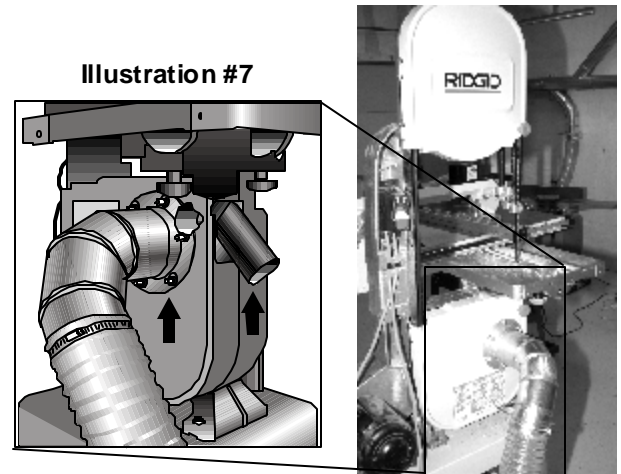
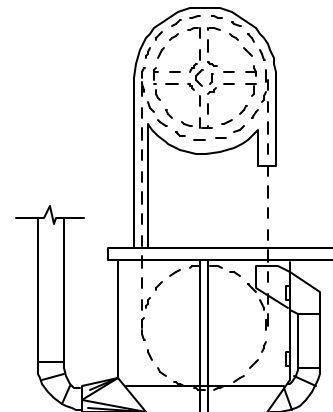

Illustration #8



Lathe, Drill Press, Scroll Saw, and Table-Mounted Routers

These machines often make dust collection difficult. They usually do not have provisions built in for it. With some improving, the majority of fine dust that is the major health risk can be captured. Standard reducers or rectangular to round hoods can be used for dust ports on drill presses, router tables and scroll saws. These hoods can be mounted to the tool beds with clamps for easy adjustment. A short length of straight pipe or flex hose held under steady rest with a large rubber band can be used for a dust port on a lathe (see ill. 9).

Illustration #9

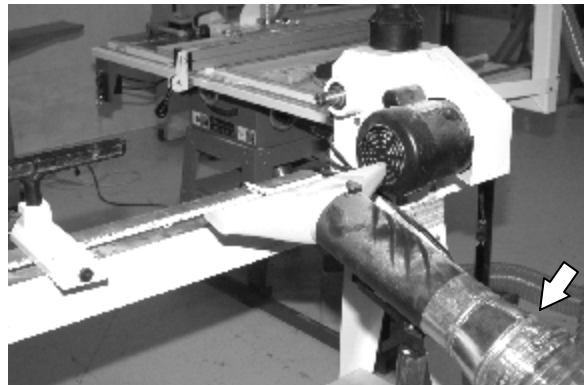

Oneida Air General Purpose Hoods

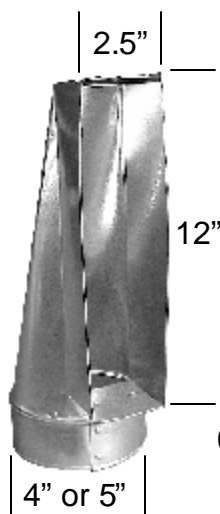

**Radial Arm Saw /
Miter Saw Hood**

DOR040000
DOR050000

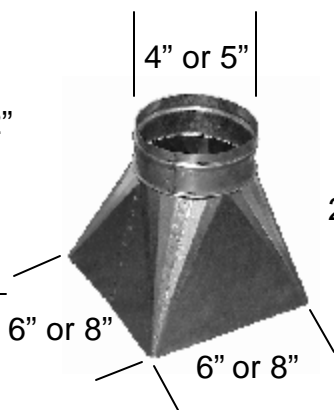

Square Hood

DOS040606
DOS050808

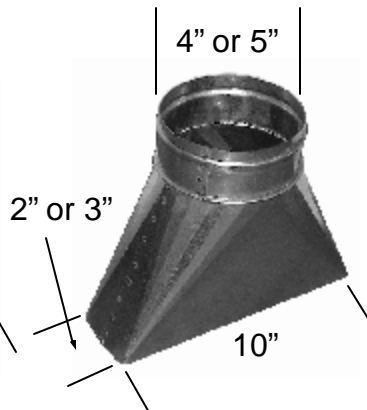

Rectangular Hood

DOT041002
DOT051003



Round Hood

DOU041009
DOU051209

FAQ's

What will happen if I turn the collector on with all of the blast gates closed? Will it burn out the motor? Why not?

It does not hurt the collector motor when all of the blast gates are closed. Closing the blast gates shuts off the air flow to the fan. The fan is doing "no work" so amperage draw drops. You can only overload the motor by not having enough resistance. For example, turning the collector on without the dust bin in place or running the fan without connecting it to a cyclone separator or ductwork.

Can I paint my ductwork?

Galvanized metal is weather resistant and will not rust unless the protective zinc coating is nicked or scratched. If you wish to paint your pipe, you must do the following: 1. Wash down all parts with an industrial de-greaser. 2. Apply a light coat of epoxy primer. 3. Then apply a coat of an acrylic water base paint.