

# Sears

## owners manual

**MODEL NO.**  
**113.249070**

Serial  
Number \_\_\_\_\_  
Model and serial  
number may be found  
at the right-hand side of  
the platform channel.  
You should record both  
model and serial number  
in a safe place for  
future use.

### CAUTION:

Read **GENERAL** and  
**ADDITIONAL SAFETY**  
**INSTRUCTIONS**  
carefully.

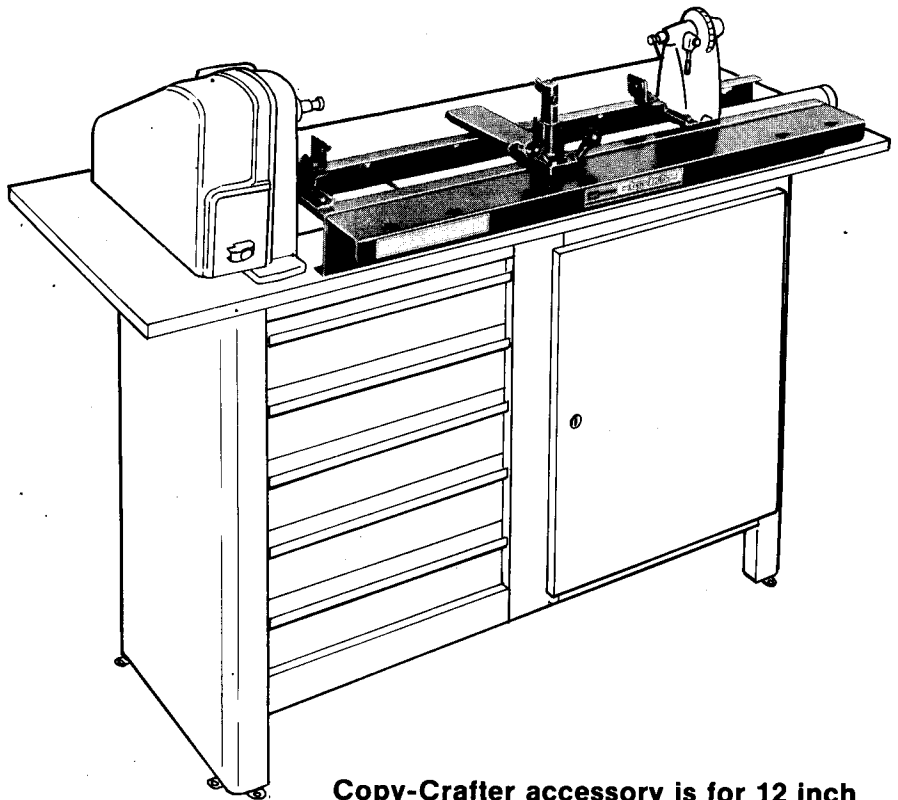

Copy-Crafter accessory is for 12 inch  
Craftsman wood lathes with tubular bed  
only. It is shown mounted on a Craftsman  
Workbench and Lathe.

Sears

**CRAFTSMAN®**

# —Copy-Crafter—

- *assembly*
- *operating*
- *repair parts*

Sold by SEARS, ROEBUCK AND CO., Chicago, IL. 60684 U.S.A.

## FULL ONE YEAR WARRANTY ON CRAFTSMAN COPY-CRAFTER

If within one year from the date of purchase, this Craftsman Copy-Crafter fails due to a defect in material or workmanship, Sears will repair it, free of charge.

WARRANTY SERVICE IS AVAILABLE BY SIMPLY CONTACTING THE NEAREST SEARS STORE OR SERVICE CENTER THROUGHOUT THE UNITED STATES.

This warranty gives you specific legal rights, and you may also have other rights which vary from state to state.

SEARS, ROEBUCK AND CO., Dept. 698/731A, Sears Tower, Chicago, IL 60684

Before operating the Copy-Crafter read and understand your Lathe and Copy-Crafter owner's manuals and affixed warnings.

The General Safety Instructions which follow apply to your Lathe and Copy-Crafter in combination as a "power tool."

## general safety instructions

- 1. KNOW YOUR POWER TOOL**  
Read the owner's manual(s) carefully. Learn its application and limitations as well as the specific potential hazards peculiar to this tool.
- 2. GROUND ALL TOOLS**  
This tool is equipped with an approved 3-conductor cord and a 3-prong grounding type plug to fit the proper grounding type receptacle. The green conductor in the cord is the grounding wire. Never connect the green wire to a live terminal.
- 3. KEEP GUARDS IN PLACE**  
in working order, and in proper adjustment and alignment.
- 4. REMOVE ADJUSTING KEYS AND WRENCHES**  
Form habit of checking to see that keys and adjusting wrenches are removed from tool before turning it ON.
- 5. KEEP WORK AREA CLEAN**  
Cluttered areas, floors and benches invite accidents. Floor must not be slippery due to wax or sawdust.
- 6. AVOID DANGEROUS ENVIRONMENT**  
Don't use power tools in damp or wet locations or expose them to rain. Keep work area well lighted. Provide adequate surrounding work space.
- 7. KEEP CHILDREN AWAY**  
All visitors should be kept a safe distance from work area.
- 8. MAKE WORKSHOP KID-PROOF**  
- with padlocks, master switches, or by removing starter keys.
- 9. DON'T FORCE TOOL**  
It will do the job better and safer at the rate for which it was designed.
- 10. USE RIGHT TOOL**  
Don't force tool or attachment to do a job it was not designed for.
- 11. WEAR PROPER APPAREL**  
Do not wear loose clothing, gloves, neckties or jewelry (rings, wrist watches) to get caught in moving parts. Nonslip footwear is recommended. Wear protective hair covering to contain long hair. Roll long sleeves above the elbow.
- 12. USE SAFETY GOGGLES (Head Protection)**  
Wear Safety goggles (must comply with ANSI Z87.1) at all times. Also, use face or dust mask if cutting operation is dusty, and ear protectors (plugs or muffs) during extended periods of operation.
- 13. SECURE TOOL FIXTURES**  
Support cutting tool with tool rest or tool post.
- 14. DON'T OVERREACH**  
Keep proper footing and balance at all times.
- 15. MAINTAIN TOOLS WITH CARE**  
Keep tools sharp and clean for best and safest performance. Follow instructions for lubricating and changing accessories.
- 16. DISCONNECT TOOLS**  
before servicing, and when changing accessories.
- 17. AVOID ACCIDENTAL STARTING**  
Make sure switch is in "OFF" position before plugging in. If a power failure occurs while operating, turn switch "OFF" and remove switch key.
- 18. USE RECOMMENDED ACCESSORIES**  
Consult the owner's manual for recommended accessories. Follow the instructions that accompany the accessories. The use of improper accessories may cause hazards.

**19. NEVER STAND ON TOOL**

Serious injury could occur if the tool is tipped.

Do not store materials above or near the tool such that it is necessary to stand on the tool to reach them.

**20. CHECK DAMAGED PARTS**

Before further use of the tool, a guard or other part that is damaged should be carefully checked to ensure that it will operate properly and perform its intended function. Check for alignment of moving parts, binding

of moving parts, breakage of parts, mounting, and any other conditions that may affect its operation. A guard or other part that is damaged should be properly repaired or replaced.

**21. DIRECTION OF ROTATION**

Consult owners manual for proper direction of spindle rotation.

**22. NEVER LEAVE TOOL RUNNING UN-ATTENDED**

Turn power off. Don't leave tool until it comes to a complete stop.

## additional safety instructions for copy-crafter

**Before operating the Copy-Crafter read and understand your Lathe and Copy-Crafter owner's manuals and affixed Warnings.**

**1. Preparation of workpiece**

Before attempting to copy (duplicate) a spindle turning, rough out the workpiece using the conventional lathe tools and lathe tool rest. Use lowest speed when starting - never exceed recommended speed on lathe "spindle speed" chart.

Before attempting to copy (duplicate) a faceplate turning, saw the corners off the workpiece.

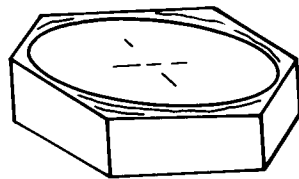

Mount the workpiece (see "Getting to Know Your Copy-Crafter"). Use lowest speed when starting - never exceed recommended speed on Lathe "spindle speed" chart. Use conventional lathe tools and tool rest to turn periphery. Use conventional lathe tools and tool rest (or Bowl Turning Tool Rest - Cat. No. 9-24903) for internal turnings deeper than 3/4 inches.

2. Do not force the cutting tool into the revolving workpiece, or attempt to take a heavy cut. This could damage the workpiece or cause it to come out of the lathe. This is especially true of long workpieces of small diameter.

Always take light cuts and make sure that the centers are seated properly in the workpiece.

3. Wear safety goggles at all times. Wear face shield or mask if operation is dusty.

4. Stop operation immediately if the turning vibrates or if abnormal noise occurs.

5. Tighten all screws, nuts and locknuts securely before operating.

6. Note and follow the instructions found on the WARNING label which appears on the flange of the platform channel.

### WARNING: FOR YOUR OWN SAFETY

- 1. READ AND UNDERSTAND LATHE AND COPY-CRAFTER OWNERS' MANUALS AND AFFIXED WARNINGS BEFORE OPERATING THIS MACHINE.
- 2. USE LOWEST SPEED WHEN STARTING A NEW WORKPIECE—NEVER EXCEED RECOMMENDED SPEED ON LATHE "SPINDLE SPEED" CHART.

- 3. WEAR SAFETY GOGGLES.
- 4. TURN WORKPIECE OVER BY HAND TO CHECK CLEARANCE TO TOOL, TOOL REST, AND ORIGINAL TURNING OR TEMPLATE.
- 5. DO NOT TURN A SPLIT WORKPIECE OR ONE CONTAINING A KNOT.



The operation of any power tool can result in foreign objects being thrown into the eyes, which can result in severe eye damage. Always wear safety goggles complying with ANSI Z87.1 (shown on Package) before commencing power tool operation. Safety Goggles are available at Sears retail or catalog stores.

# unpacking and checking contents

## TOOLS NEEDED



Pliers

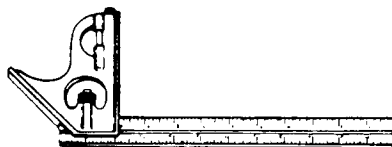

Combination Square

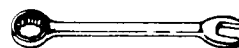

1/2 in. Wrench

The Copy-Crafter is shipped unassembled in one carton in order to facilitate packaging. The step by step instructions that follow explain how to assemble the Copy-Crafter and how to make a project.

Before starting to assemble the Copy-Crafter, we suggest you read this entire manual first to become familiar with the names and location of the various parts and how they function.

Make sure that all of the items are removed from the carton. Identify them as shown in the illustration on page 24. The following illustrations will help you to identify some of the hardware.

Also see List of Loose Parts on page 26.

### ROUND HEAD CARRIAGE BOLTS

- 9 Required 2 inches long
- 10 Required 3/4 inches long

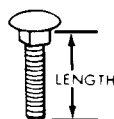

### SOCKET HEAD SET SCREWS

- 2 Required 1-3/4 inches long
- 2 Required 1/2 inches long
- 2 Required 1-1/4 inches long with sharp point



### HEXAGON HEAD BOLT

- 1 Required 1-1/2 inches long

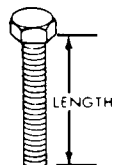

### FLANGE NUTS

- 18 Required



### PLAIN HEXAGON NUTS

- 15 Required



### CENTER SCREW

- 1 Required 1-1/4 inches long



### WASHERS

- 8 Required



## TABLE OF CONTENTS

Warranty .....	2	Getting to Know Your Copy-Crafter .....	10
General Safety Instructions .....	2	Operation .....	14
Additional Safety Instructions for the Copy-Crafter .....	3	Making Practice Cuts .....	14
Unpacking and Checking Contents .....	4	Duplicating from a Template (Starter Project) .....	17
Assembly .....	5	Duplicating a spindle from an existing one .....	21
Bed .....	5	Repair Parts .....	24
Mounting Copy-Crafter to lathe bench .....	6	List of Loose Parts .....	26
Tool holder .....	7		
Brackets .....	9		

# assembly

## BED ASSEMBLY

The Copy-Crafter Bed is made up of (3) three Channels held together by Tie Rods. All (3) three Channels are the same except one has the Copy-Crafter label. This is the Front Channel. The other (2) two are Vertical Channels.

1. Assemble the Front Channel and (1) one of the Vertical Channels as shown using (2) two Round Head Carriage Bolts 3/4 inches long and (2) Flange Nuts.

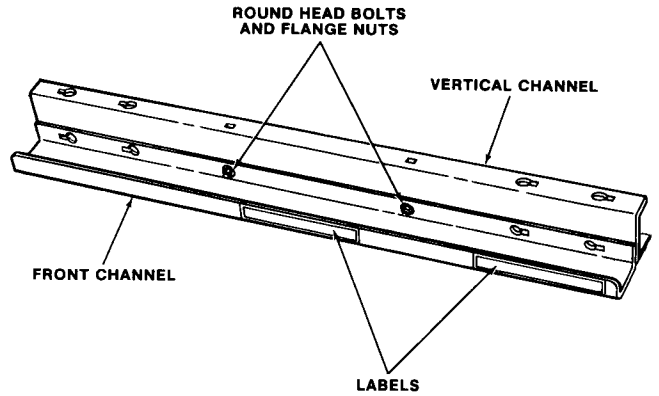

2. Screw (2) two Plain Hexagon Nuts and (2) Flange Nuts on each Tie Rod as shown. The Flange Nuts should be equal distance from each end of the Tie Rods.

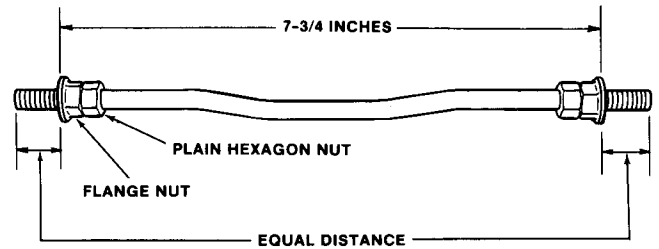

3. Hold the Flange Nut on the end of each Tie Rod with a 1/2 inch wrench or pliers and using another 1/2 inch wrench, tighten the Plain Hexagon Nut firmly against the Flange Nut as shown.

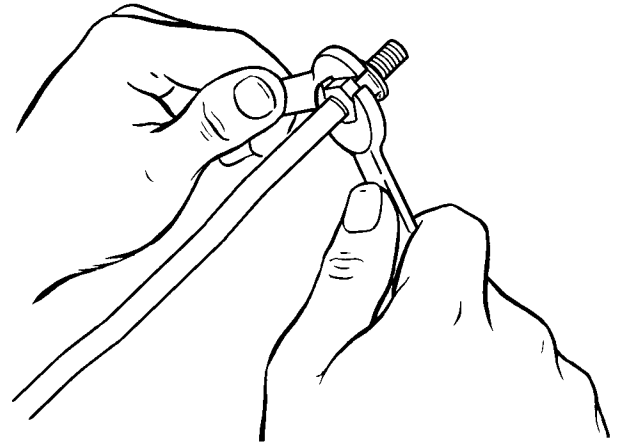

4. Lay the Channels on a flat surface and line up the ends of the Channels using a combination square as shown.
5. Insert the Tie Rods into the second Key Hole from the end of each Vertical Channel. The bend in the Tie Rods should face downward.
6. Move the Tie Rods into the square portion of the Key Holes.
7. With the Channels still in line, screw a Flange Nut on the end of each Tie Rod as shown. Tighten the Flange Nut.

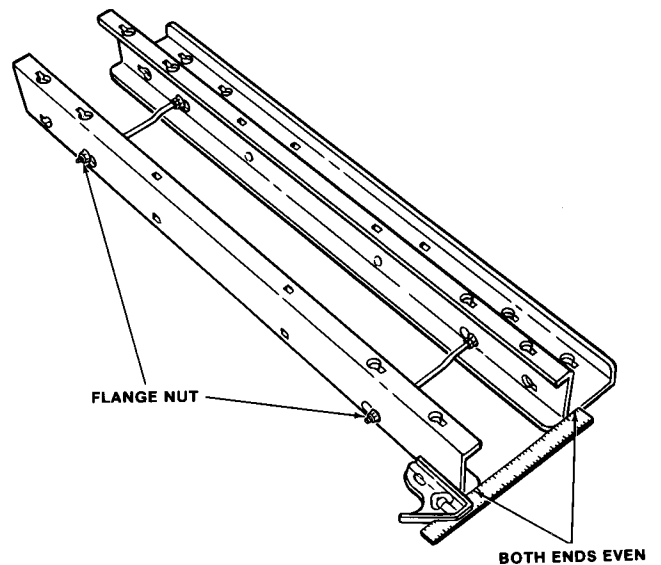

# assembly

## MOUNTING COPY-CRAFTER BED TO LATHE BENCH

1. Remove the Tool Rest Base and locking hardware from the Lathe (see your Lathe Owners Manual) and place the Tailstock approximately 24 inches from the Headstock.

**NOTE:** If your Lathe has a Tool Rest Bracket and locking hardware like the one shown in this illustration, be sure to unscrew the Threaded Slide and remove it from the Tool Rest Bracket as shown before mounting the Copy-Crafter bed.

REMOVE THIS THREADED SLIDE FROM THE TOOL REST BRACKET BEFORE MOUNTING COPY-CRAFTER

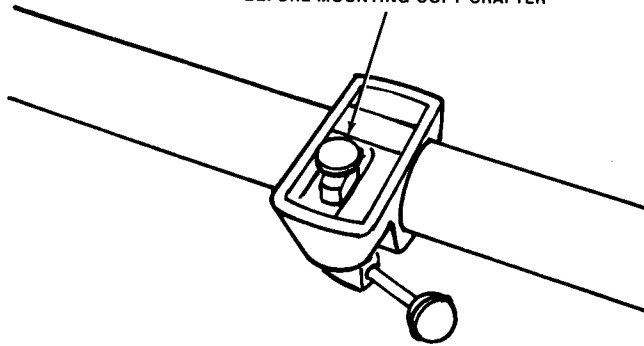

2. Position the Copy-Crafter Bed on the Lathe Bench so that the Lathe Bed is between the two Vertical Channels of the Copy-Crafter and the Copy-Crafter label faces the operator.

The front Vertical Channel should be 3-1/4 inches from the Lathe Bed and 1/2 inch from the foot of the Headstock as shown.

3. Check this distance at the other end making sure it is also 3-1/4 inches. The Copy-Crafter Bed should now be parallel to the Lathe Bed.

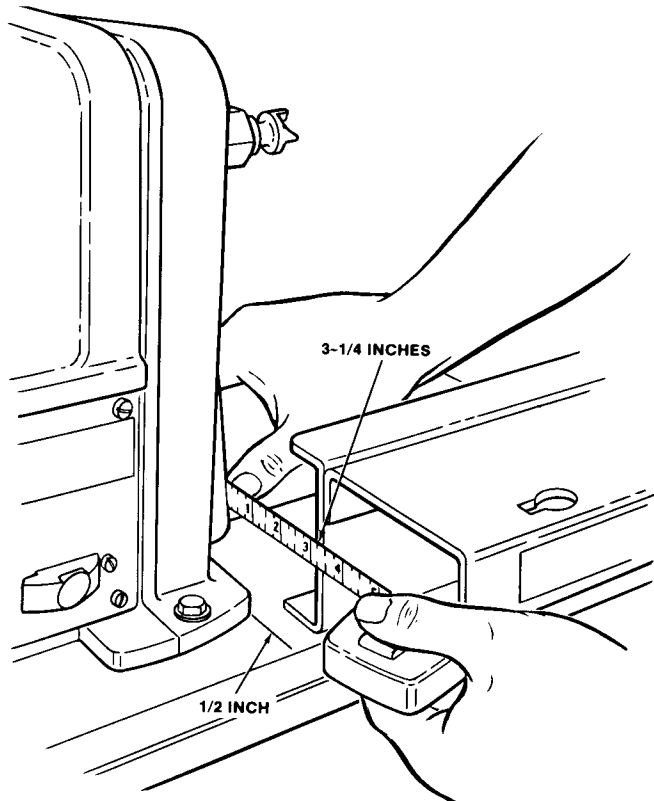

4. Without moving the Copy-Crafter Bed, carefully mark location of 8 bolt holes.

- a. Trace the square portion of the Key Hole at the end of each Vertical Channel.
- b. Trace the 2 square holes in the center of each Vertical Channel. You may have to move the Tailstock to trace these holes.

5. Remove the Copy-Crafter Bed and drill 3/8-inch holes in the center of the marked squares.
6. Attach the Copy-Crafter Bed to the Lathe Bench using (8) eight Round Head Carriage Bolts, (2) two inches long and Flange Nuts.

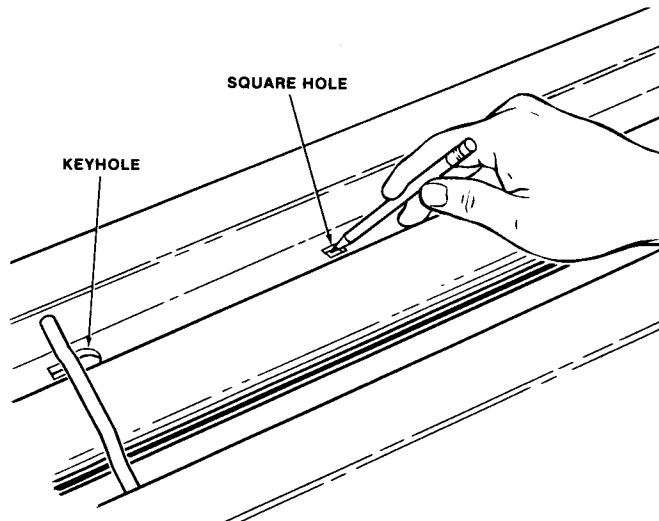

# assembly

7. The Front Channel should be slightly lower than the top of the Vertical Channels. Check the height with a combination square as shown. If it is higher, loosen the Flange Nuts and lower it.

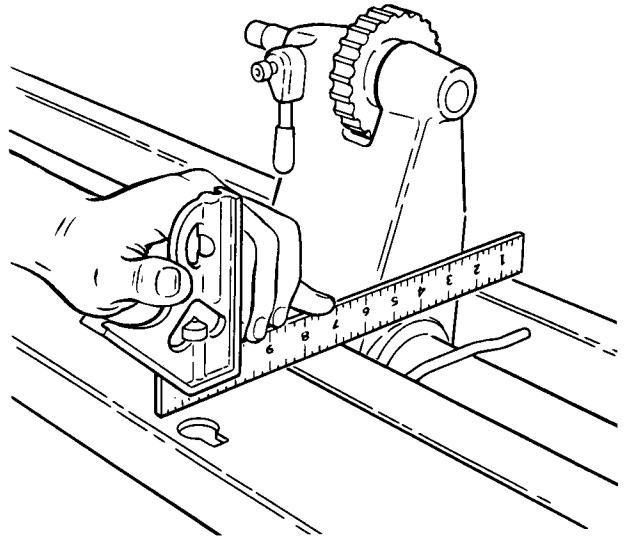

---

## TOOL HOLDER

1. Screw a 1-3/4 inch long socket head screw tightly into each Knob as shown.

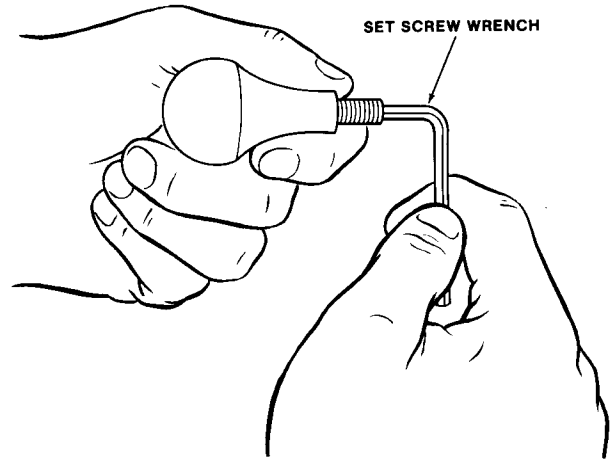

2. Screw a Square Nut onto each of the Follower Pins.  
**NOTE:** The Nut has four dots on one side. . .they must face the threaded end.

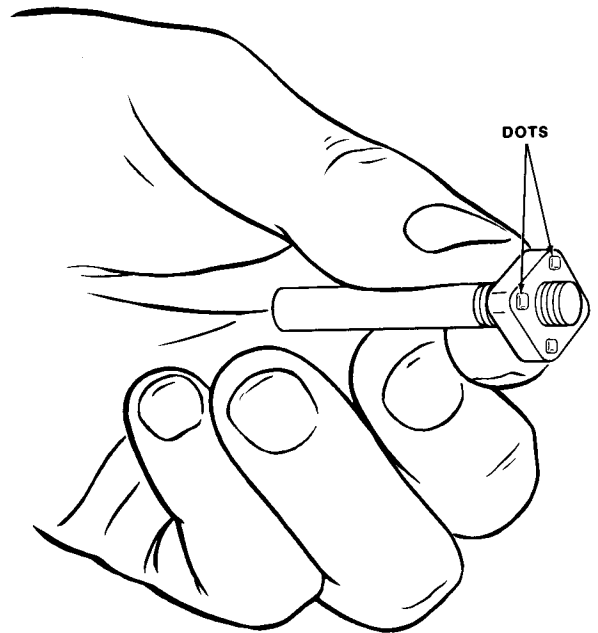

# assembly

3. Screw the Knobs and Follower Pins into the Tool Post Base. (see illustration).
4. Insert the Tool Post.
5. Screw a 1/2 inch long Socket Head Screw into the top of the Tool Post and into the Tool Post Base a few turns; do not tighten.

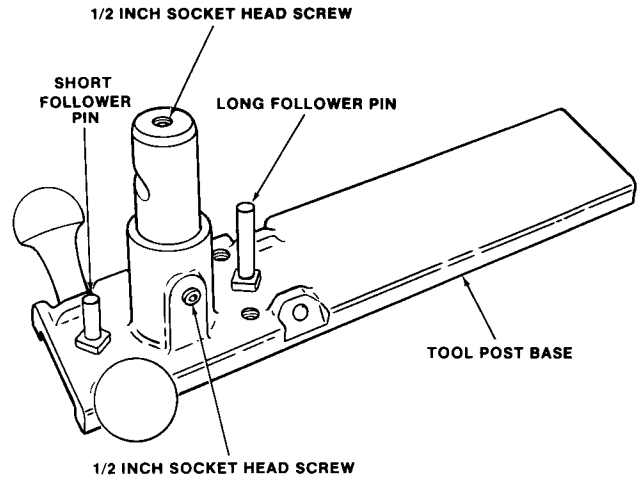

6. An Alignment Gauge is provided to align the tip of the Cutting Tool with the centerline of the Lathe (see page 11, number 8). The following steps explain how this is done.
  - a. Measure the distance from the top of the Square Nut to the point of the Spur Center as shown.

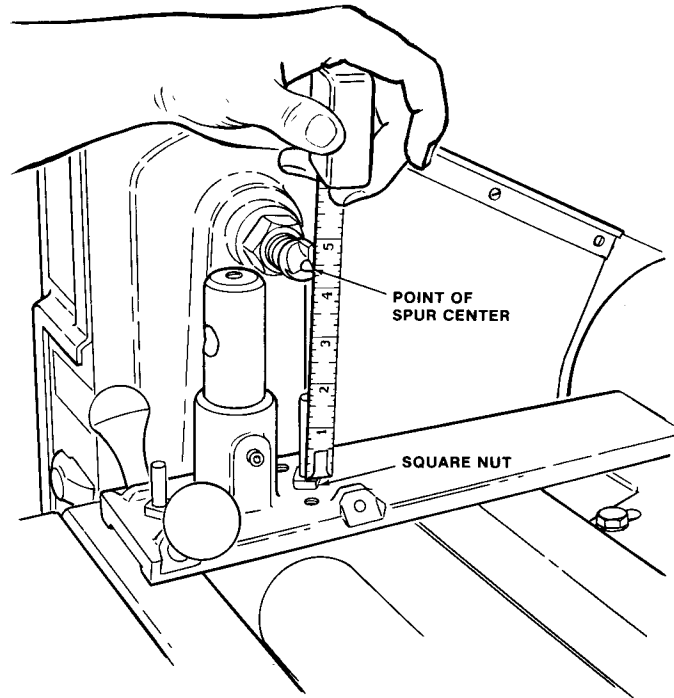

- b. Using a sharp pointed instrument, scratch a mark on both inside surfaces of the Alignment Gauge as shown. The distance between the scratch line and one end of the Alignment Gauge should be equal to the above measurement.

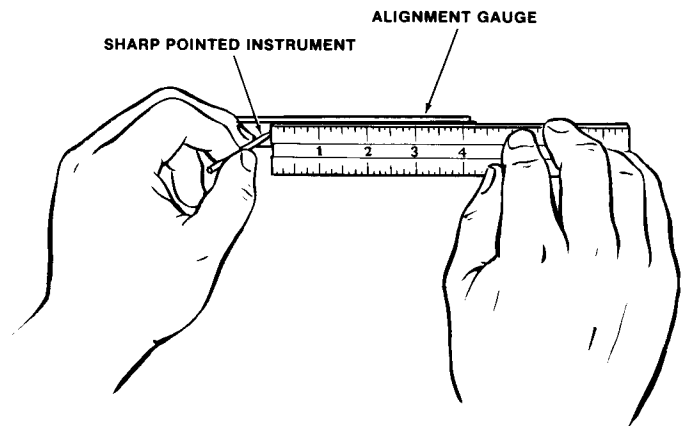



# assembly

- c. Remove protective coating from the tip of the Cutting Tool and place it in the Cradle.
- d. Insert the Cutting Tool and Cradle into the Tool Post and rotate it back and forth while turning the Set Screw in the top of the Tool Post. The Set Screw should seat into cove in the top of the Cutting Tool.

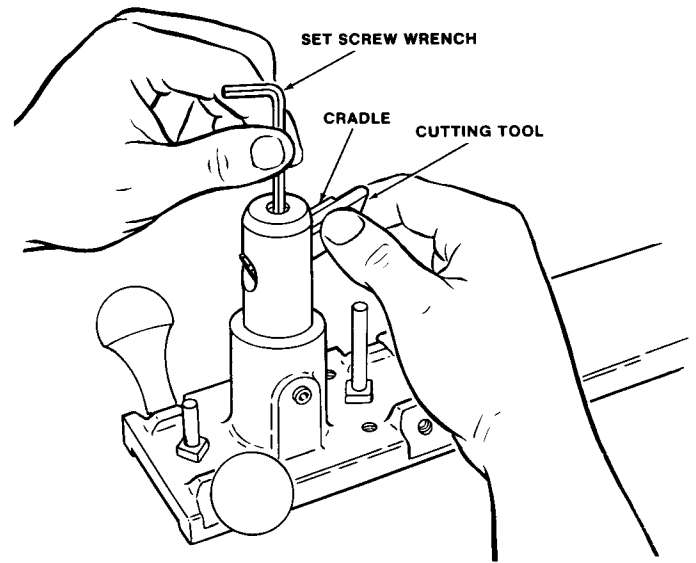

- e. Hold Alignment Gauge tightly against Follower Pin . . . make sure it is resting on top of Square Nut.
- f. Push Cutting Tool gently against Gauge making sure that it touches both inside surfaces of Gauge by rotating Tool Post. This will align the tip of the Cutting Tool with the Follower Pin.
- g. While still holding Gauge firmly against Follower Pin, raise Tool Post until tip of Cutting Tool is even with scratch mark on Gauge. Tighten Setscrew in Tool Post Base.
- h. Tighten Setscrew in top of Tool Post. The tip of the Cutting Tool should now be directly above the Follower Pin as high as the centerline of the lathe.

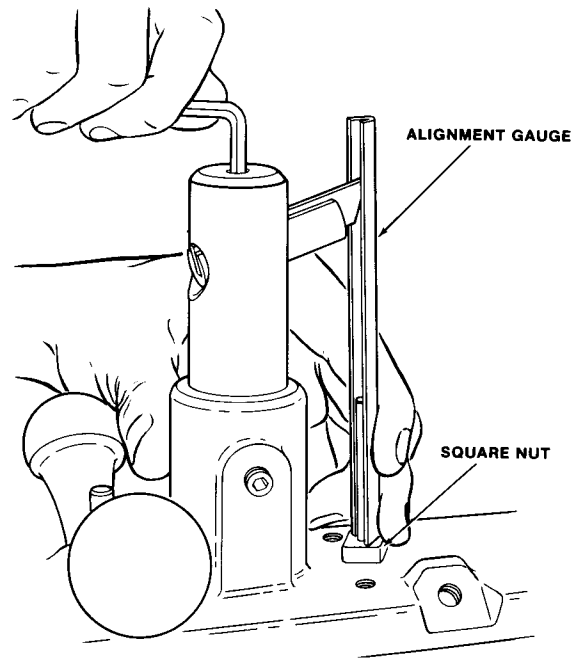

## BRACKETS

1. Assemble the right and left Brackets using 3/4 inch long Round Head Bolts, Washers and Plain Hexagon Nuts. Install on the bed as shown.

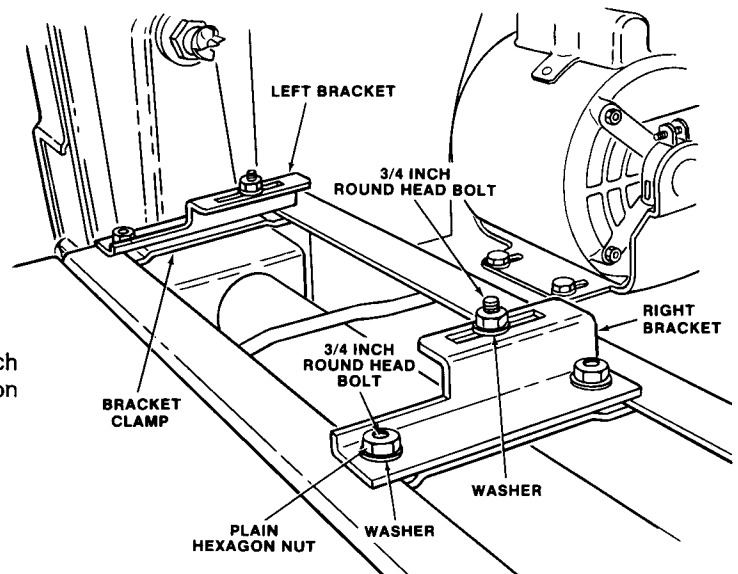

# getting to know your copy-crafter

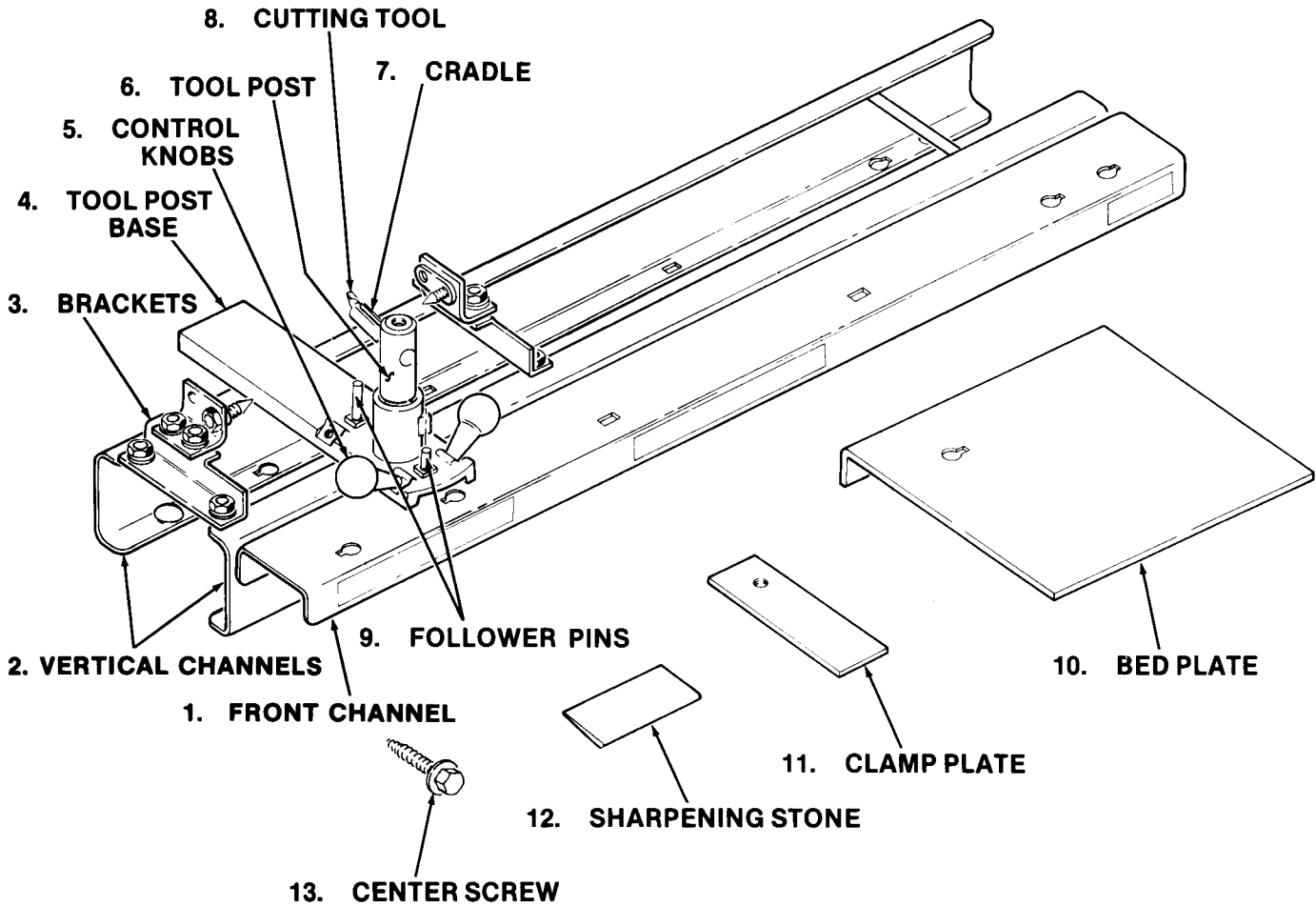

1. **FRONT CHANNEL.** . .comfortably supports your hands while maneuvering the Cutting Tool.
2. **VERTICAL CHANNELS.** . .support the Tool Post Base and the Brackets.
3. **BRACKETS.** . .hold the template or an existing turning.
4. **TOOL POST BASE.** . .supports the Tool Post and contains the control Knobs and the Follower Pins.

There are two strips of very slippery plastic tape glued to the underside so that it moves easily during operation. Be careful not to tear these tapes by bumping the base against a sharp object.

Should the tapes become damaged or worn, replace them. (See replacement parts list in the back of this manual).

# getting to know your copy-crafter

5. **CONTROL KNOBS.** . .provide a comfortable means for maneuvering the Cutting Tool. They are screwed into the holes in the end of the Tool Post for duplicating spindle turnings and into the opposite holes for duplicating faceplate turnings.
6. **TOOL POST.** . .supports the Cutting Tool and the Cutting Tool Cradle. It can be swiveled to the right or left for various types of cuts.
7. **CRADLE.** . .supports the Cutting Tool and enables it to be locked in the center of the Tool Post.
8. **CUTTING TOOL.** . .must always be sharp for best cutting results. The tip must always be set at the centerline of the Lathe (not above or below it), directly above the Follower Pin (not in front of it or in back of it.)

**NOTE:** The Cutting Tool may have a slight burr on the cutting edge when received from the factory. If so it will be necessary to remove this burr before operating the Copy-Crafter to assure a smooth cut.

To remove the burr, follow the sharpening instructions on page 13, number 12 of this manual.

9. **FOLLOWER PINS.** . .follow the edge of the template or existing turning and gauge the cutting action of the Tool.

The longer pin is screwed into the middle hole in the base located in back of the Tool Post, and is used for duplicating spindle turnings. It can be positioned in the holes on the right or the left for certain types of undercutting.

The Shorter Pin is screwed into the hole in front of the Tool Post, and is used for duplicating faceplate turnings.

- 
10. **BED PLATE.** . .supports the tool holder or the Lathe Tool Rest while duplicating faceplate turnings. It is secured to the bed by the nut on the Tie Rod.

The plate contains a "key hole" which is used for attaching the Lathe Tool Rest. Use the washer from your Craftsman Wood Lathe and a 2 inch round head bolt and a plain hexagon nut furnished with your Copy-Crafter.

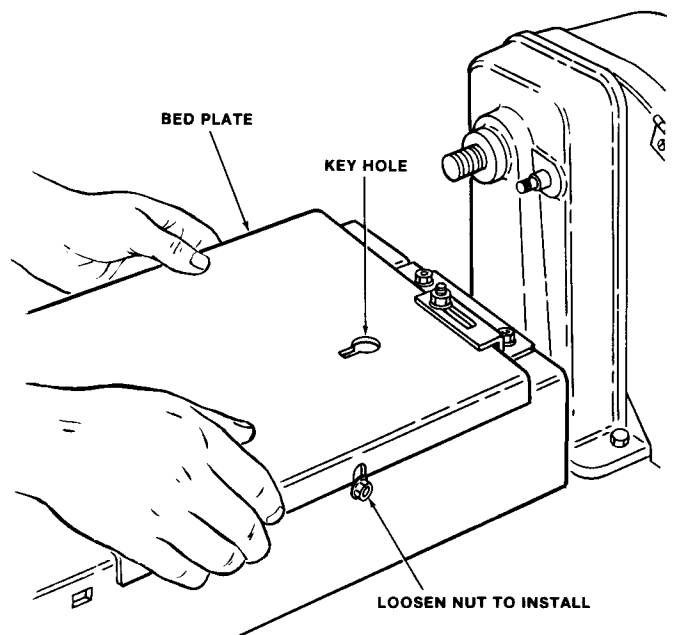

# getting to know your copy-crafter

**11. CLAMP PLATE.** . .holds the Lathe Tool Rest to the Vertical Channels for rough turning to the general shape and cleaning up sharp corners on the finished turnings. The tool Rest should be set approximately  $\frac{1}{8}$  inch below the centerline of the Lathe and approximately  $\frac{1}{8}$  inch away from the workpiece.

**NOTE:** The shank length can vary from one Tool Rest to another and in some cases may be slightly too long. Measure the shank on your Tool Rest and if they are longer than  $1\frac{7}{8}$  inches, cut them off with a hacksaw. Clamp the Tool Rest in a vise as shown. Do not clamp it on the shank or on the machined top surface as this would cause burrs.

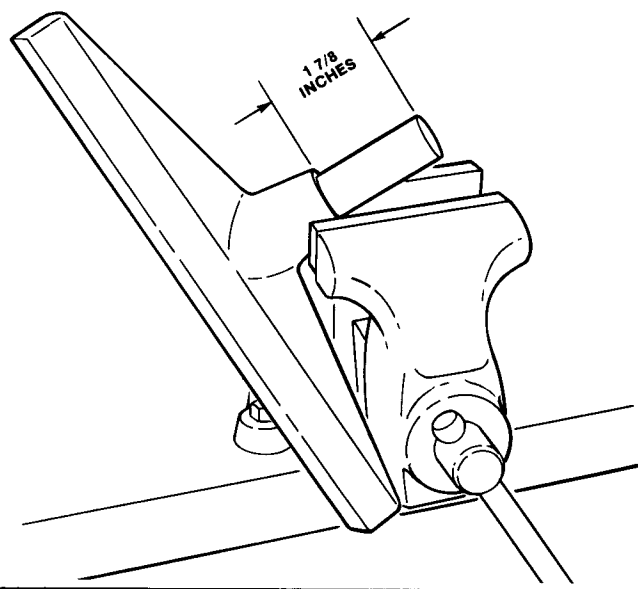

Remove the large washer and spring from the tool rest holder on your Craftsman Lathe and fasten them to the Clamp Plate with the  $1\frac{1}{4}$  inches long Hexagon Head screw furnished with your Copy-Crafter.

For large diameter turnings, place the Tool Holder on the plate and position it on the Vertical Channels as shown for rough turning or finishing.

**NOTE:** The Clamp Plate is underneath both Channels.

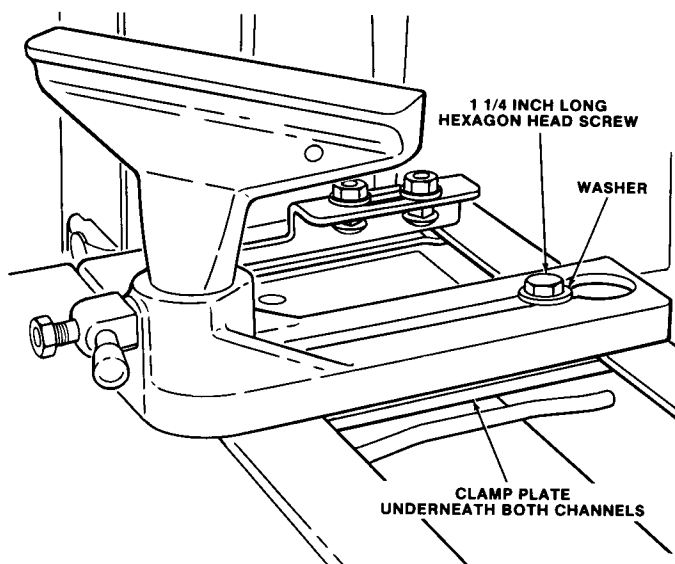

For small diameter turnings, the back end of the Clamp Plate is underneath the back Channel while the front end is on top of the near Channel. This permits the Tool Rest to be positioned close to the turning.

Be sure the Tool Rest Holder and the Tool Rest are locked securely before operating.

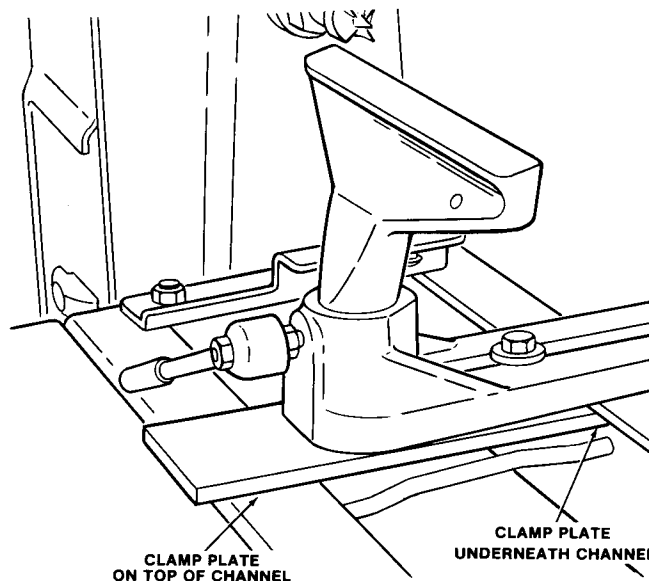

# getting to know your copy-crafter

**12. SHARPENING STONE.** . .is provided for frequent sharpening of the Cutting Tool. **REMEMBER THAT WHEN THE TOOL IS SHARP, HALF OF THE JOB IS DONE.**

Apply a generous amount of light household oil (Do not use motor oil) to the stone, and with a circular motion hone the entire rounded edge of the tool while holding it firmly.

Make sure the stone is always in contact with the entire length of the rounded end. . .do not just hone the point.

Honing will cause a burr to appear on the tip of the tool which must be removed.

Hold the tool firmly while carefully sliding the stone straight up and down in the groove on the top side until the burr is removed. A slight burr may now appear on the rounded end which must be removed.

Repeat honing the rounded end and the groove until the burr disappears.

Always move the stone in a straight line. . .do not "rock it," otherwise you will "round over" the cutting edge and the tool will be dull.

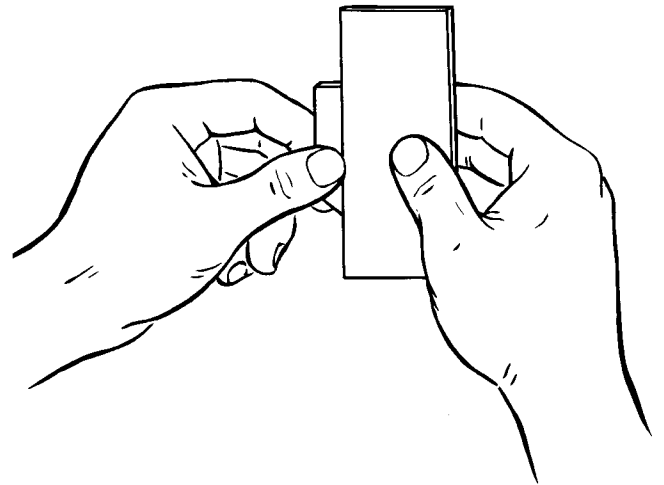
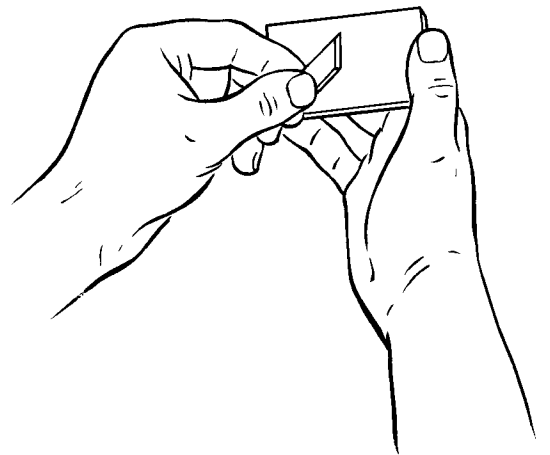

**13. CENTER SCREW.** . .is a large pointed screw 1-1/4 inches long with a hexagon head that contains a screwdriver slot. It is used for attaching the workpiece to either the 4 or the 6 inch diameter faceplate which is fitted with a "backing."

Make the backing out of one of the following:

- 3/4 inch thick hardwood, or
- 3/4 inch thick plywood, or
- 2 pieces of 3/8 inch plywood glued together, or
- 3 pieces of 1/4 inch plywood glued together. Cut the wood approximately 1/2 inch larger in diameter than the faceplate.

# getting to know your copy-crafter

Cut two slots 180° apart to fit the tip of the screwdriver. This will allow you to hold the Faceplate while unscrewing the workpiece.

Attach the Backing to the Faceplate with three #12 or #14 x 3/4 inch flathead wood screws.

Turn the backing round and true up the face so that it is approximately 1/32 inch low in the center.

With the Lathe running at 2250 R.P.M. make a mark in the center and drill a 11/64 inch diameter hole all the way through. If you do not have a chuck for your wood lathe, drill the hole with a drill press or a portable drill. **DO NOT REMOVE THE BACKING FROM THE FACEPLATE.** If you do, it will be difficult to replace it in exactly the same position on the Faceplate.

Screw the **CENTER SCREW** tightly into the center hole in the backing.

To make sure that the workpiece does not rotate around the Center Screw, drill a 3/16 inch diameter hole through the backing at one of the vacant screw holes in the Faceplate. Insert a #6 or #8 wood screw, 1 inch long, and screw it into the workpiece. When turning the workpiece, do not hit the screw with the Cutting Tool.

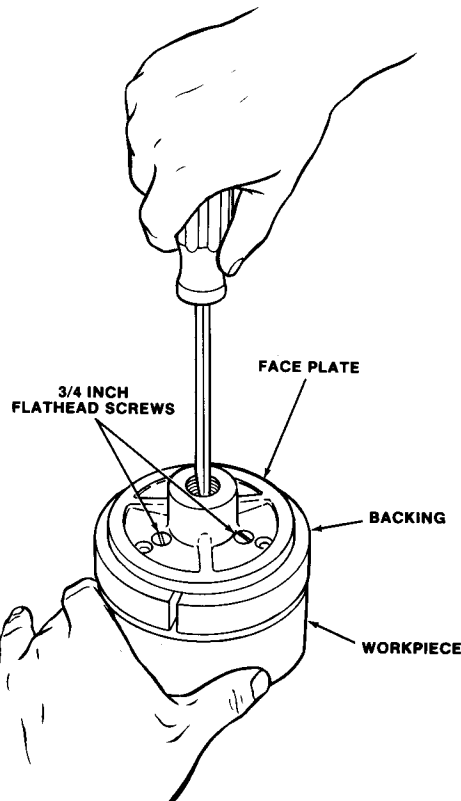
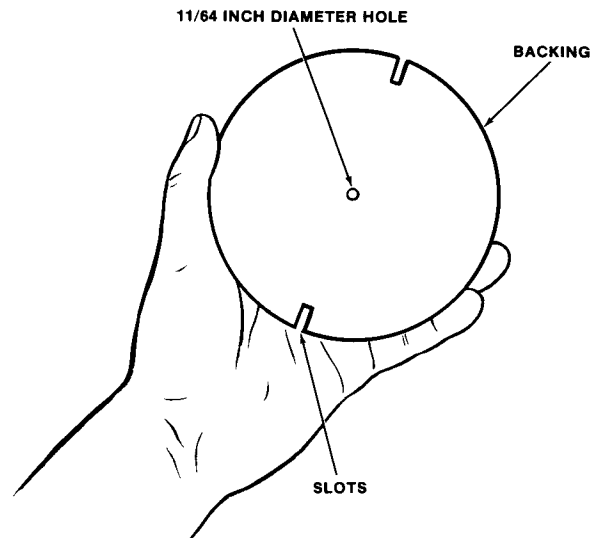

---

## operation

### MAKING PRACTICE CUTS

1. Duplicating a turning is done in three stages:
  - a. Rough turning to the general shape using the Gouge and the Tool Rest.
  - b. Finish turning on the Copy-Crafter
  - c. Cleaning up sharp corners using the Parting Tool, Spear Point, or Skew, and the Tool Rest.

Before starting a project, first gain some experience by making practice cuts on a piece of scrap wood. . . say a piece of hardwood 2 inches square and 12 inches long.

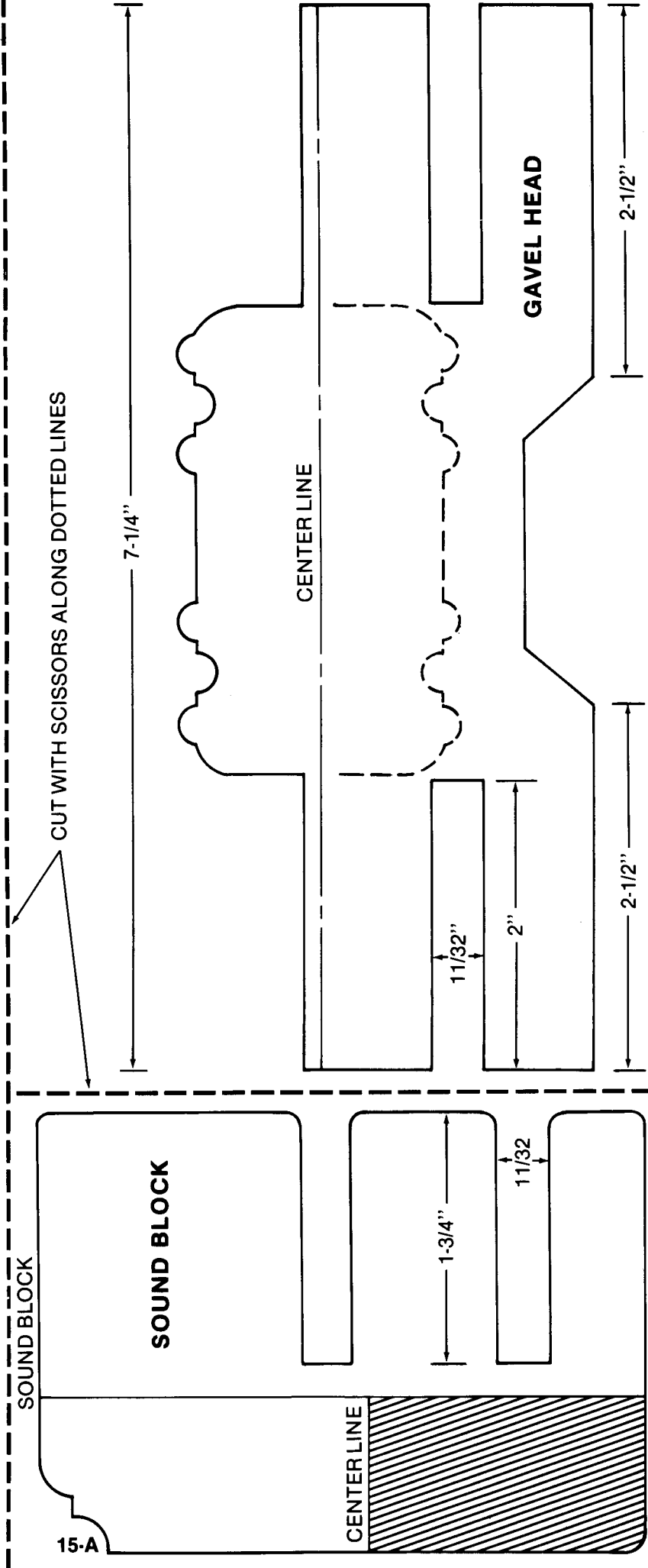
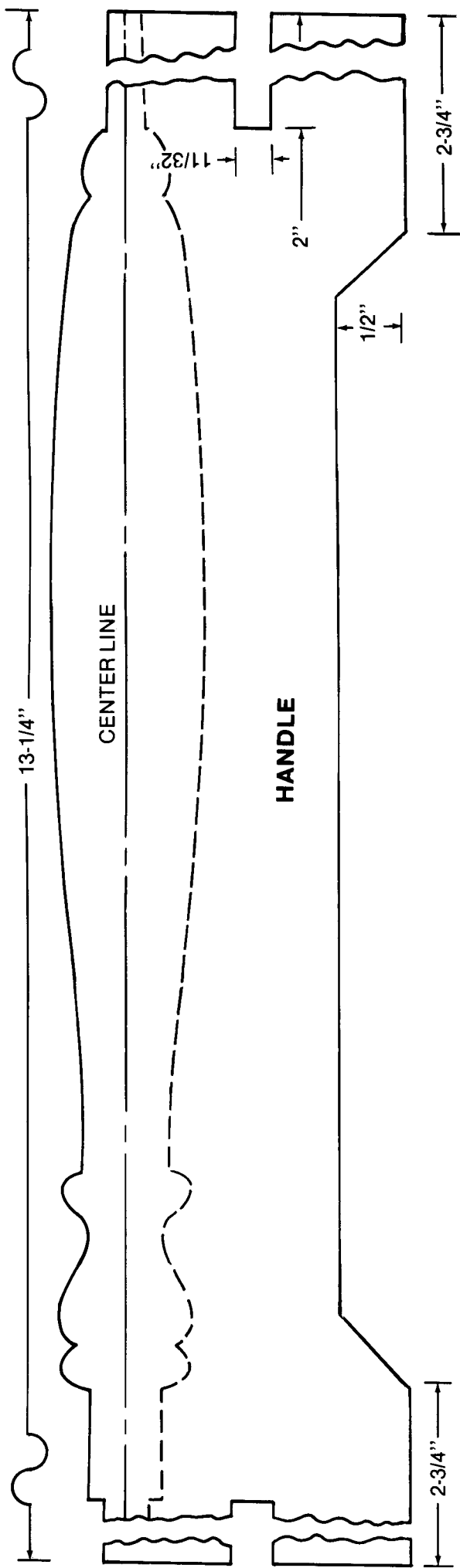





# operation

## DUPLICATING FROM A TEMPLATE

Here are instructions for two simple projects which will familiarize you with making templates, and then duplicating from them.

### STARTER PROJECT: GAVEL AND SOUND BLOCK

1. Remove page 15A from this manual and cut with scissors along dotted lines.

**NOTE:** The pattern for the handle is full size, however the overall length of the template must be 13 1/4 inches. Pay particular attention to dimensions of the ends of the template.

2. Glue the full size patterns to a piece of 1/8 inch or 1/4 inch thick tempered hardboard or plywood. Carefully cut them out and smooth up the edges with a file.
3. Glue a straight strip of wood to the template to reinforce it.

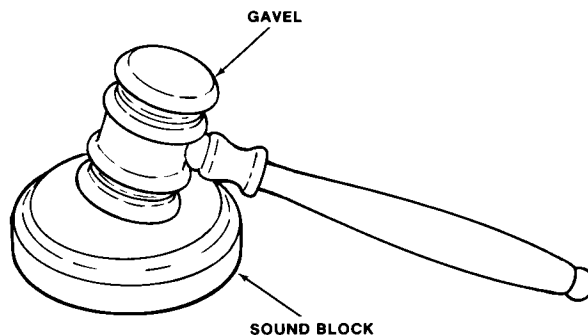

4. The spur center and cup centers of the Lathe should be in alignment.

If the centers are not in line as shown, make the following adjustments.

- a. Make sure the tailstock and ram are locked when checking for alignment.
- b. Loosen the screw in the foot. . .TAP the screw to loosen the locknut inside.
- c. Using a 3/16" setscrew wrench, loosen the setscrew on the back of the headstock. The screw is located about 1-3/4" from the bottom.
- d. Swing the tailstock so that the two points are in line. . .tighten the setscrew in the headstock and the tailstock.

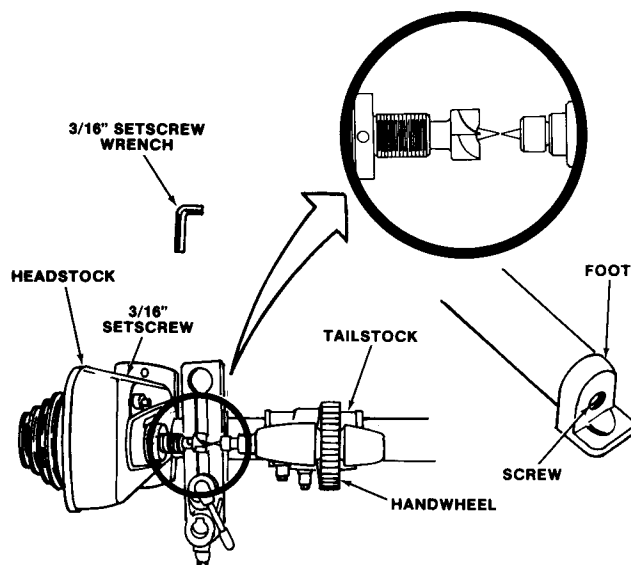

5. Attach the pattern to the Brackets. The Round Head Bolts in the top of each Bracket fits into the slot in each end of the pattern as shown.
6. The centerline of the pattern must be directly in line with the centerline of the lathe. Use a combination square to align the centerline of the pattern with the points of the spur and cup centers as shown. Tighten the nuts and bolts securing the pattern to the Bracket.

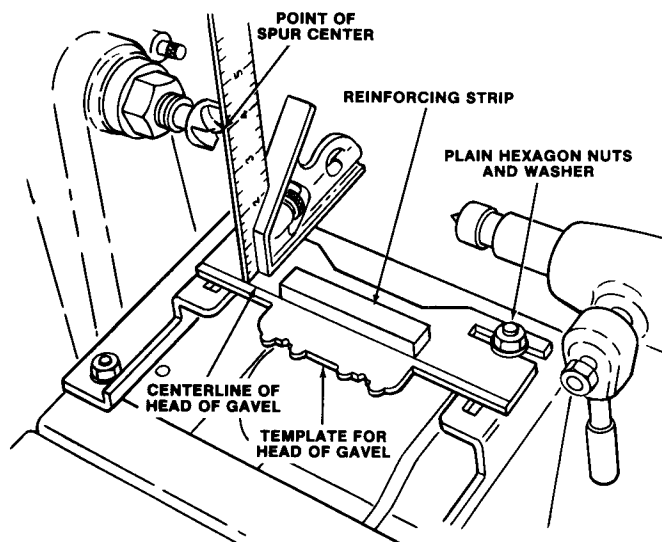

# operation

7. Select a piece of wood 2-1/2 inches square and 5-1/4 inches long for the head of the gavel.
8. Turn it round with a shoulder cut on each end.

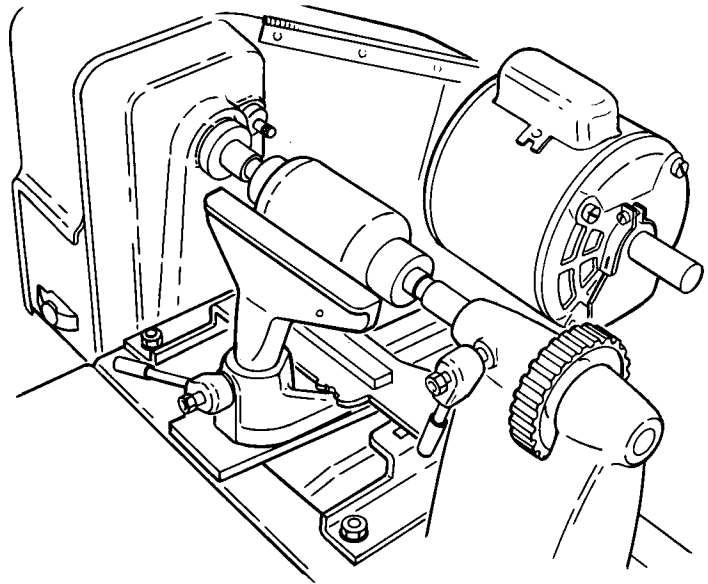

9. Finish turning to the template.

Maneuver the Cutting Tool by moving your wrists while the sides of your hands rest on the Front Channel. Take very light cuts to start with, until you get the feel of the cutting action.

The action of the Cutting Tool should be down hill toward the narrow diameter.

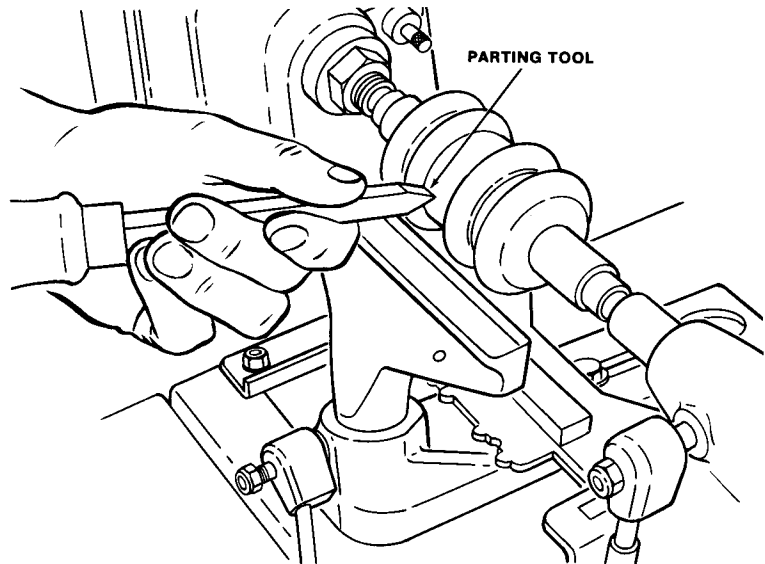
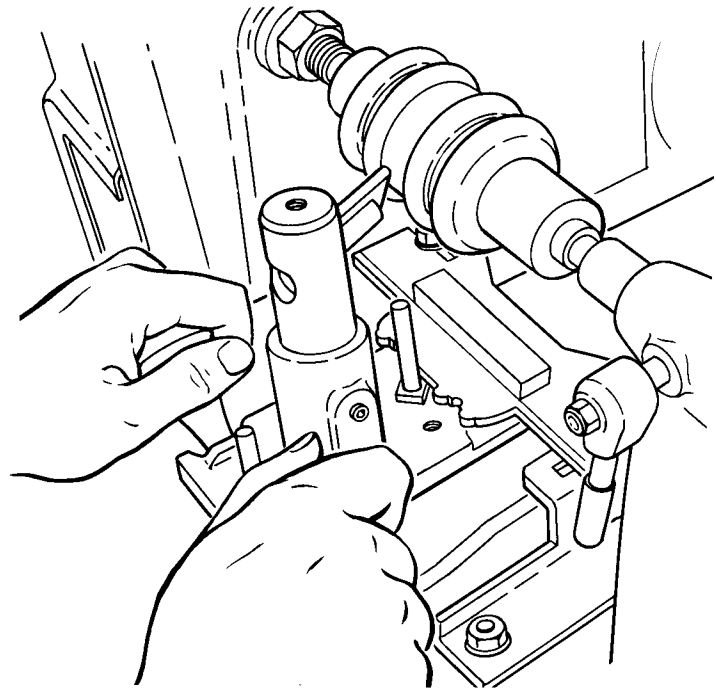

10. Clean up the sharp corners using the Parting Tool.

# operation

11. Turn down both ends to about 1/2 inch diameter.
12. Smooth up with sandpaper.
13. Remove the workpiece from the Lathe and cut the ends off. Sand smooth.
14. Select a piece of wood 1-1/4 inches square and 11-1/4 inches long for the handle of the gavel.

**NOTE:** When turning small diameters, some woods may tend to "chatter" or "vibrate" while cutting. If this happens be sure to take very light cuts. Be sure the Spur Center is tightly seated into the workpiece.

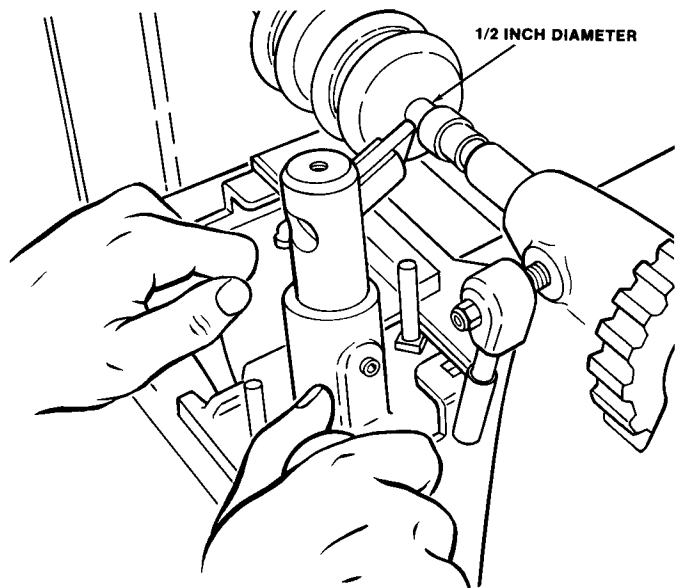

## MAKING THE SOUND BLOCK

1. Prepare the Faceplate Backing (See #13 page 13-14).
2. The sound block should be made out of the same kind of wood that was used for the gavel. To make sure that it doesn't split from pounding on it, make it out of two pieces, 1/2 inch thick and 5 inches square.
3. Glue the pieces together so that the grain of the wood of one piece is at ninety degrees to the grain of the other piece.
4. Attach the Bed Plate (See #10 page 11)
5. Align template to backing and to point of Center Screw as shown.
6. Drill an 11/64 inch diameter hole in the workpiece and screw it on the backing using a screwdriver (See page 14).

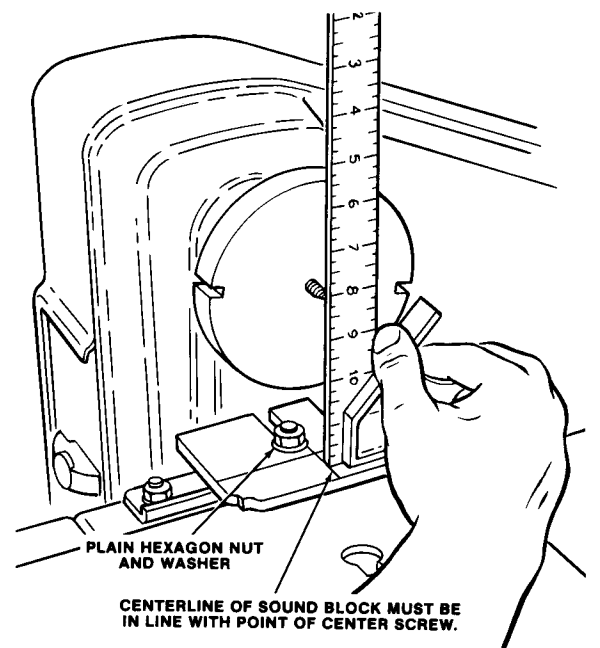
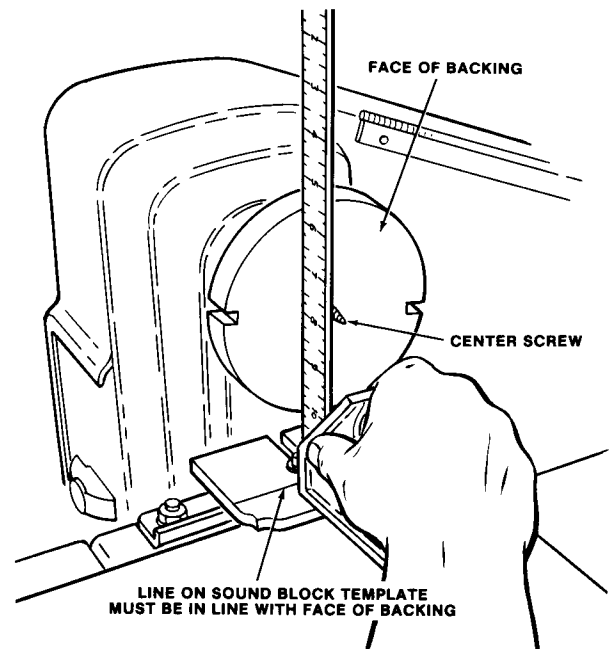

# operation

7. Attach Tool Rest (See # 10 page 11) and turn the workpiece to 4-1/2 inches in diameter.

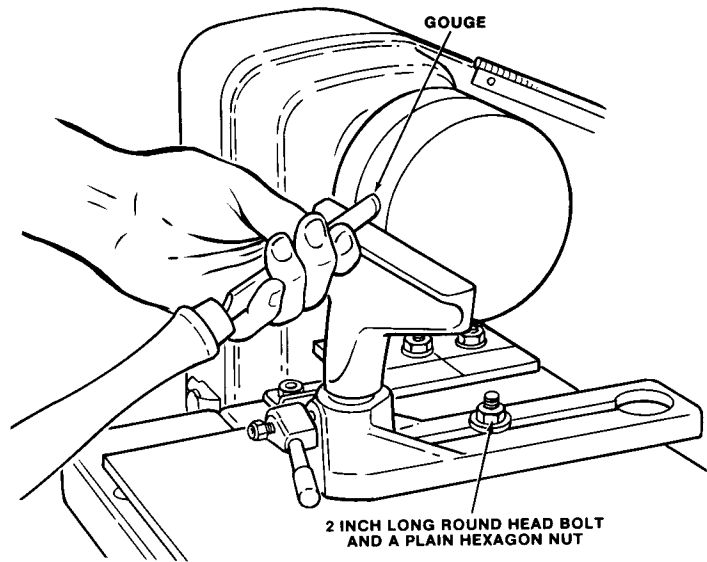

8. Rotate Tool Post 180 degrees and realign the Cutting Tool with the short Follower Pin. . screw Knobs into opposite holes for operation.

**NOTE:** When turning faceplates, do not move Cutting Tool to the right of the centerline of the Lathe.

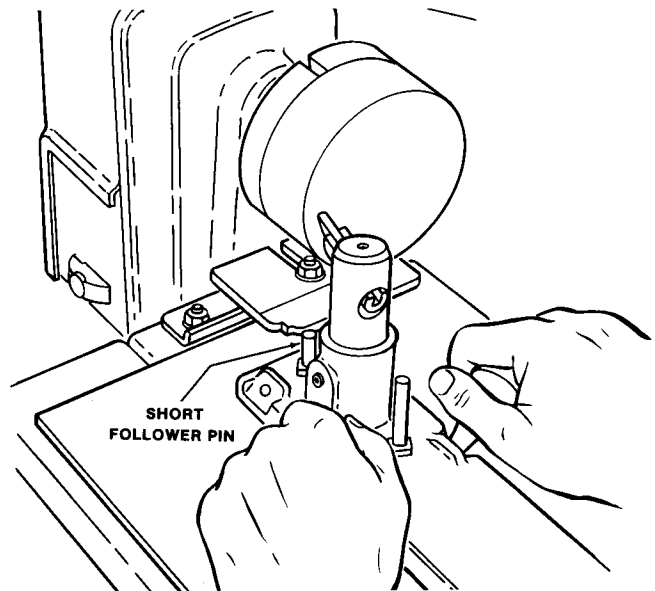

9. Attach Tool Rest and touch-up corners with the Spear Point.

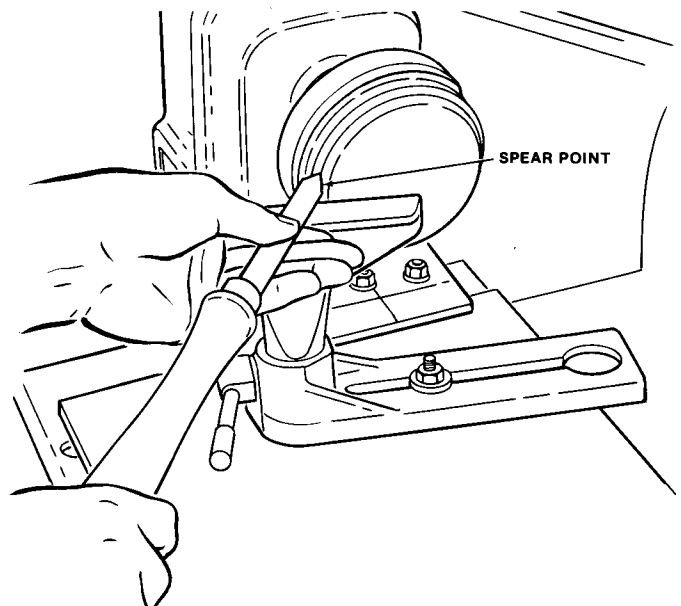

# operation

10. Insert a screwdriver into one of the slots in the backing to prevent it from turning while unscrewing the workpiece.
11. Glue a piece of felt to the bottom to prevent marring the furniture surface.

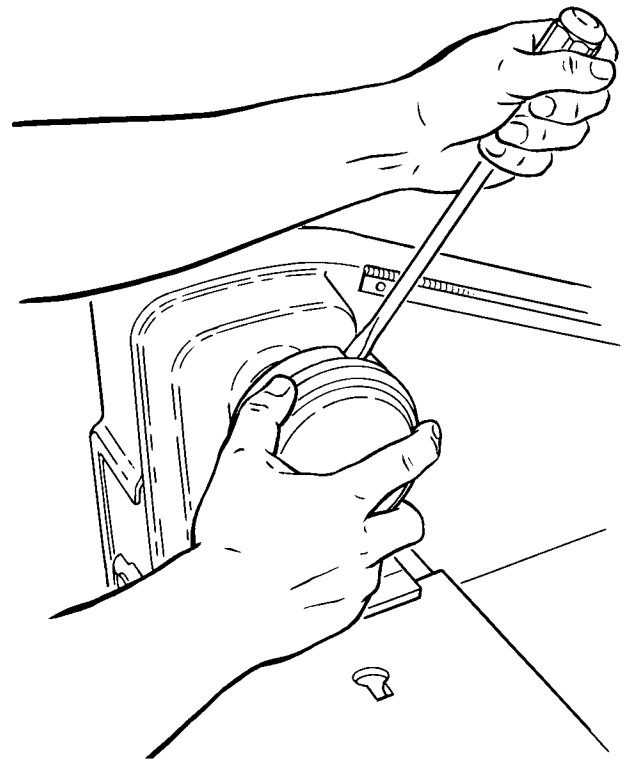

## DUPLICATING A SPINDLE FROM AN EXISTING ONE

1. Two Spindle Brackets are provided for duplicating from an existing spindle.
2. To hold an existing spindle, screw a 1-1/4 inch long Cone-Point Set Screw into each Spindle Bracket and secure with a Plain Hexagon Nut as shown.

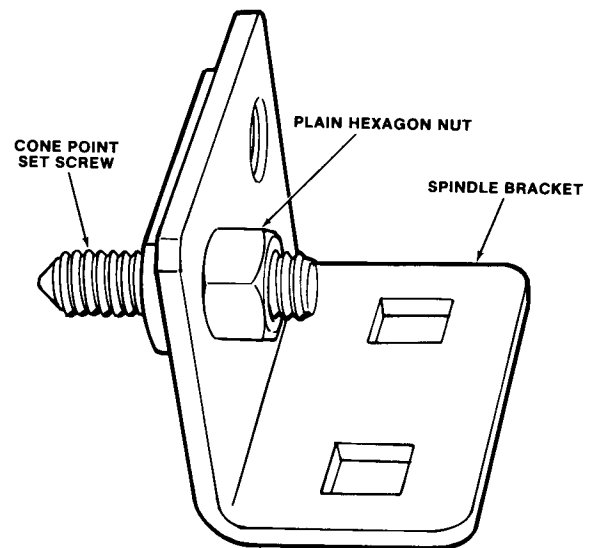

3. Attach a Spindle Bracket to the left-hand Bracket using two 3/4 inch plain Round-Head Bolts, Washers, and plain Hexagon Nuts as shown.
4. Be certain the spur and cup centers of the Lathe are in alignment see page 15 step 4.
5. Before attaching the right-hand Spindle Bracket, align the left-hand Cone-Point Set Screw with the Point of the cup center. To do so:
  - a. Remove the left Tie Rod from the Copy-Crafter.
  - b. Place the Clamp Plate or a piece of plywood across the Vertical Channels to support a combination square.
  - c. Move the tailstock next to the Headstock as shown and align the point of the Set Screw with the point of the cup center.
  - d. Without moving the Spindle Bracket, tighten the nuts and bolts securing it to the left-hand Bracket.

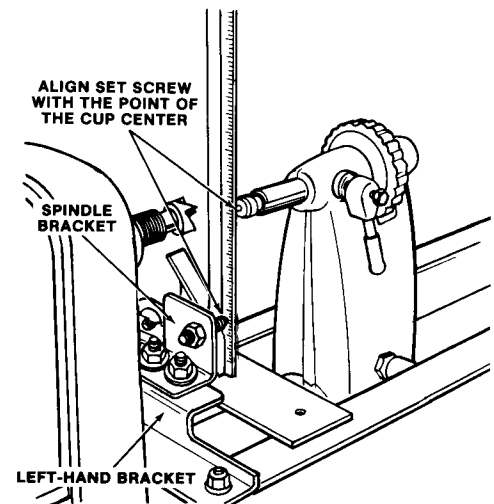

# operation

6. Return the Tailstock to the right-hand side of the Lathe bed and replace the left Tie Rod. Attach a Spindle Bracket to the right-hand Bracket. With the Clamp Plate or a piece of plywood across the Vertical Channels, align the right-hand Cone-Point Set Screw with the point in the cup center as shown.

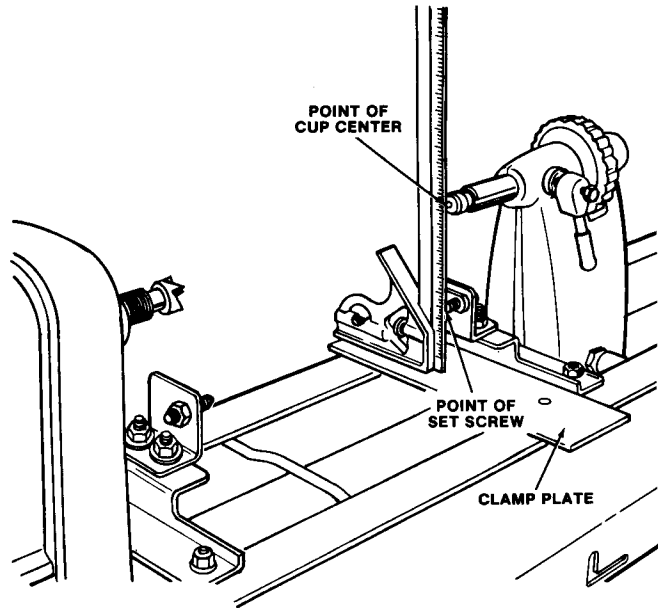

7. If the existing spindle is 2-1/2 inches in diameter or less, it can be used in place of a template.

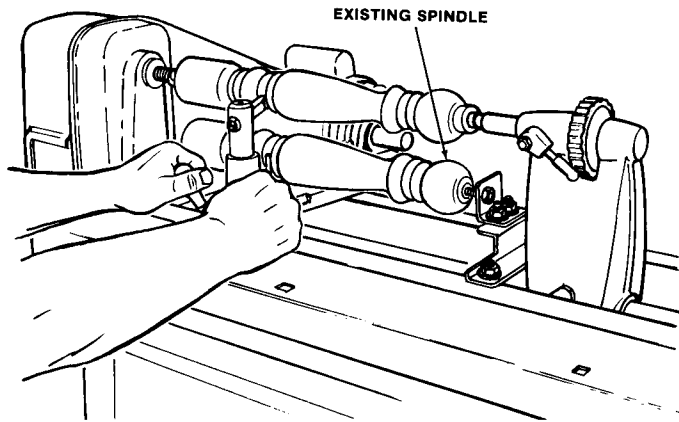

8. If the existing spindle is larger than 2-1/2 inches in diameter, it will be necessary to make a template.

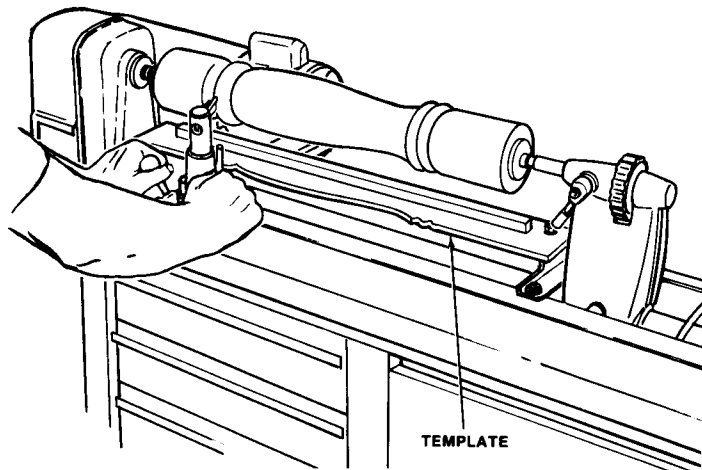

# operation

9. Use Sears Contour Gauge 9-3946 to obtain the outline of the existing spindle for the template.

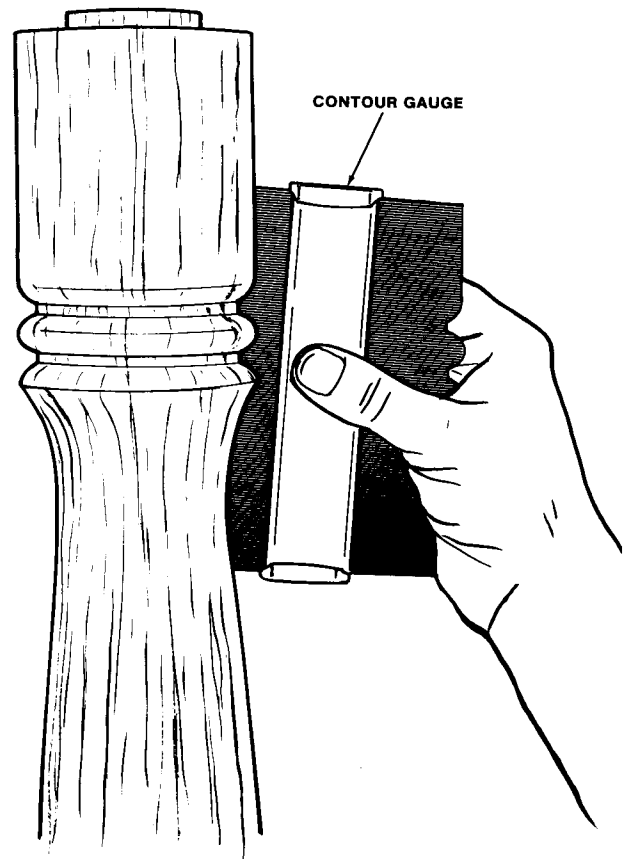

# repair parts

## PARTS LIST FOR CRAFTSMAN COPY CRAFTER MODEL 113.249070

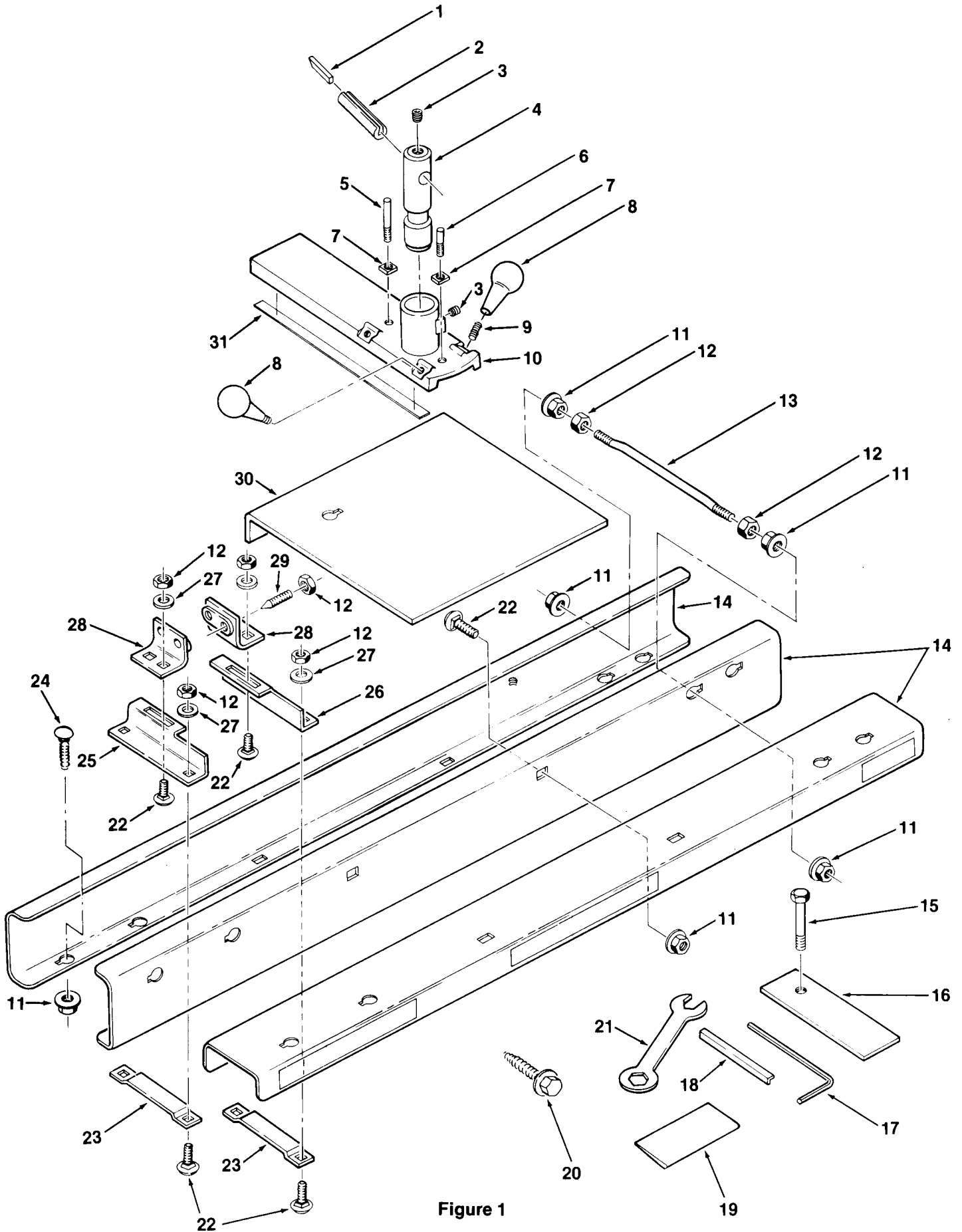

Figure 1



# repair parts

## PARTS LIST FOR CRAFTSMAN COPY-CRAFTER MODEL 113.249070

Always Order by Part Number — Not Key Number

FIGURE 1

Key No.	Part No.	Description
1	70036	Tool, Cutting
2	70035	Cradle
3	STD503105	*Screw, Socket Set 5/16-18x1/2
4	70027	Post, Tool
5	70038	Pin, Follower 2-3/8
6	70037	Pin, Follower 1-1/2
7	60355	Nut, Square 1/4-20
8	38546	Knob
9	102589	Screw, Socket Set 5/16-18x1-3/4
10	70026	Base, Tool Post (Includes Key No. 31)
11	60356	Nut, Flange 5/16-18
12	STD541031	*Nut, Hex 5/16-18
13	70030	Rod, Tie 5/16-18
14	70025	Channel
15	60336	Bolt, High Strength 5/16-18x1-1/2
16	70043	Plate, Clamp
17	37837	Wrench, Set Screw "L" 5/32
18	70040	Gauge, Alignment
19	70039	Stone, Sharpening
20	9426615	Screw, Center TYAB 1/4x1-1/4
21	68017	Wrench, 1/2
22	STD532507	*Bolt, Carriage 5/16-18x3/4
23	70033	Clamp, Bracket
24	STD533120	Bolt, Carriage 5/16-18x2
25	70031	Bracket, Template, Left
26	70029	Bracket, Template, Right
27	STD551031	*Washer 11/32x11/16x1/16
28	70032	Bracket, Spindle Mounting
29	139377	Screw, Socket Set 5/16-18x1-1/4
30	70042	Plate, Bed
31	70044	Tape
—	70028	Package, Loose Part (Not Illustrated)
—	70034	Package, Loose Parts (Not Illustrated)
—	70041	Owners Manual

\*Standard Hardware Item - May Be  
Purchased Locally.

## LIST OF PARTS IN LOOSE PARTS BAGS

	QTY.
Loose Parts Bag #70028	
(Containing the following parts:)	
Bracket, Right Template .....	1
Rod, 5/16-18 Tie .....	2
Bracket, Left Template .....	1
Bracket, Spindle Mounting .....	2
Clamp .....	2
Wrench .....	1
Post, Tool .....	1
Knob .....	2
Tool, Cutting .....	1
Gage, Tool .....	1
Loose Parts Bag #70034	
(Containing the following parts:)	
Cradle Tool .....	1
Screw, Soc. Set 5/16-18 x 1-1/4 .....	2
Pin, 1-1/2 Follower .....	1
Wrench, Hex "L" 5/32 .....	1
Pin, 2-3/8 Follower .....	1
Screw, Soc. Set 5/16-18 x 1-3/4 .....	2
Screw, Soc. Set 5/16-18 x 1/2 .....	2
Nut, Weld 1/4-20 .....	2
Screw, Hex Washer Type AB 1/4 x 1-1/4 .....	1
Carriage, Bolt 5/16-18 x 2 .....	9
Carriage, Bolt 5/16-18 x 3/4 .....	10
Nut, Hex 5/16-18 .....	15
Nut, Flange 5/16-18 .....	18
Bolt, Hi-Strength 5/16-18 x 1-1/2 .....	1
Washer, 11/32 x 11/16 x 1/16 .....	8



# Sears

**owners  
manual**

**SERVICE**

**MODEL NO.  
113.249070**

**HOW TO ORDER  
REPAIR PARTS**

# Copy-Crafter

Now that you have purchased your Copy-Crafter, should a need ever exist for repair parts or service, simply contact any Sears Service Center and most Sears, Roebuck and Co. stores. Be sure to provide all pertinent facts when you call or visit.

The model number of your Copy-Crafter will be found on a label attached to the platform channel.

WHEN ORDERING REPAIR PARTS, ALWAYS GIVE THE FOLLOWING INFORMATION:

PART NUMBER	PART DESCRIPTION
MODEL NUMBER 113.249070	NAME OF ITEM Copy-Crafter

All parts listed may be ordered from any Sears Service Center and most Sears stores. If the parts you need are not stocked locally, your order will be electronically transmitted to a Sears Repair Parts Distribution Center for handling.

**Sold by SEARS, ROEBUCK AND CO., Chicago, IL. 60684 U.S.A.**