

Rock-Solid Plywood Bench

Build this versatile workbench
in a weekend for under \$250

BY CECIL BRAEDEN

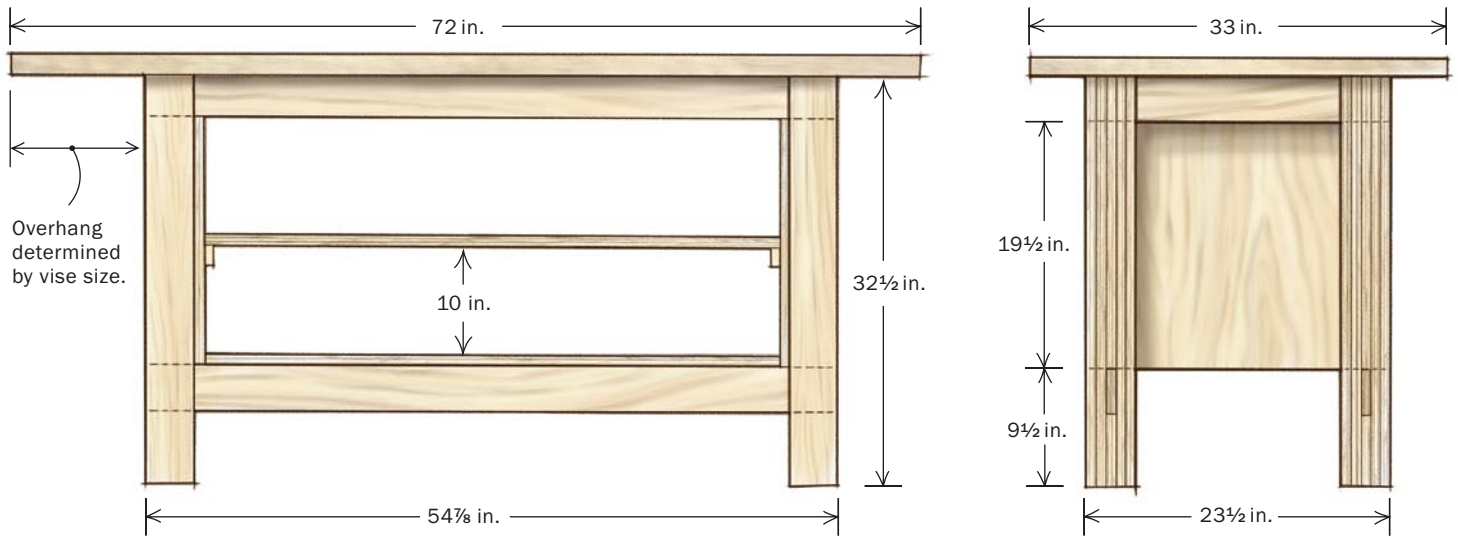

BENCHTOP DETAIL

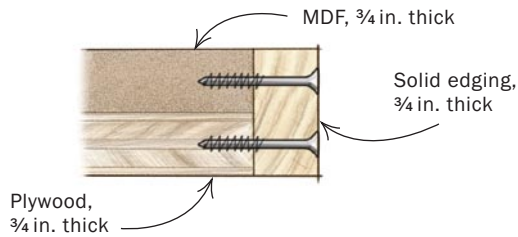

I had wanted to build a sturdy workbench for some time but was put off by the cost and complexity of a traditional hardwood bench. I knew that such benches derive much of their strength and rigidity from the mortises and tenons that join the framework, and I wondered if there was a way to combine this joinery with the inherent strength, rigidity, and dimensional accuracy of plywood. The design I created has a base of laminated sections of plywood and a top of plywood and medium-density fiberboard (MDF).

An advantage of this design is that the piece can be built without a planer or jointer, perfect for someone just getting started in woodworking. For under \$250 including a vise, I have a bench with the rigidity I desired without breaking the bank.

Design the bench, create a cut plan, and begin

This method of construction can be adapted to almost any size and type of bench: You could even construct just the base and purchase a ready-made hardwood top. My bench is 33 in. wide by 72 in. long by 34 in. tall, a comfortable height for me to work at. It is also 1/8 in. lower than my tablesaw, allowing me to use the bench as an auxiliary outfeed table. The cut plan I used (see p. 56) allows you to create a bench with legs up to 36 in. long, giving a bench height of 37 1/2 in.

All base components—legs, aprons, and stretchers—are laminations made from 3 9/16-in.-wide slats of 3/4-in.-thick plywood. Set the tablesaw's fence and rip all the strips without changing the setting. You always

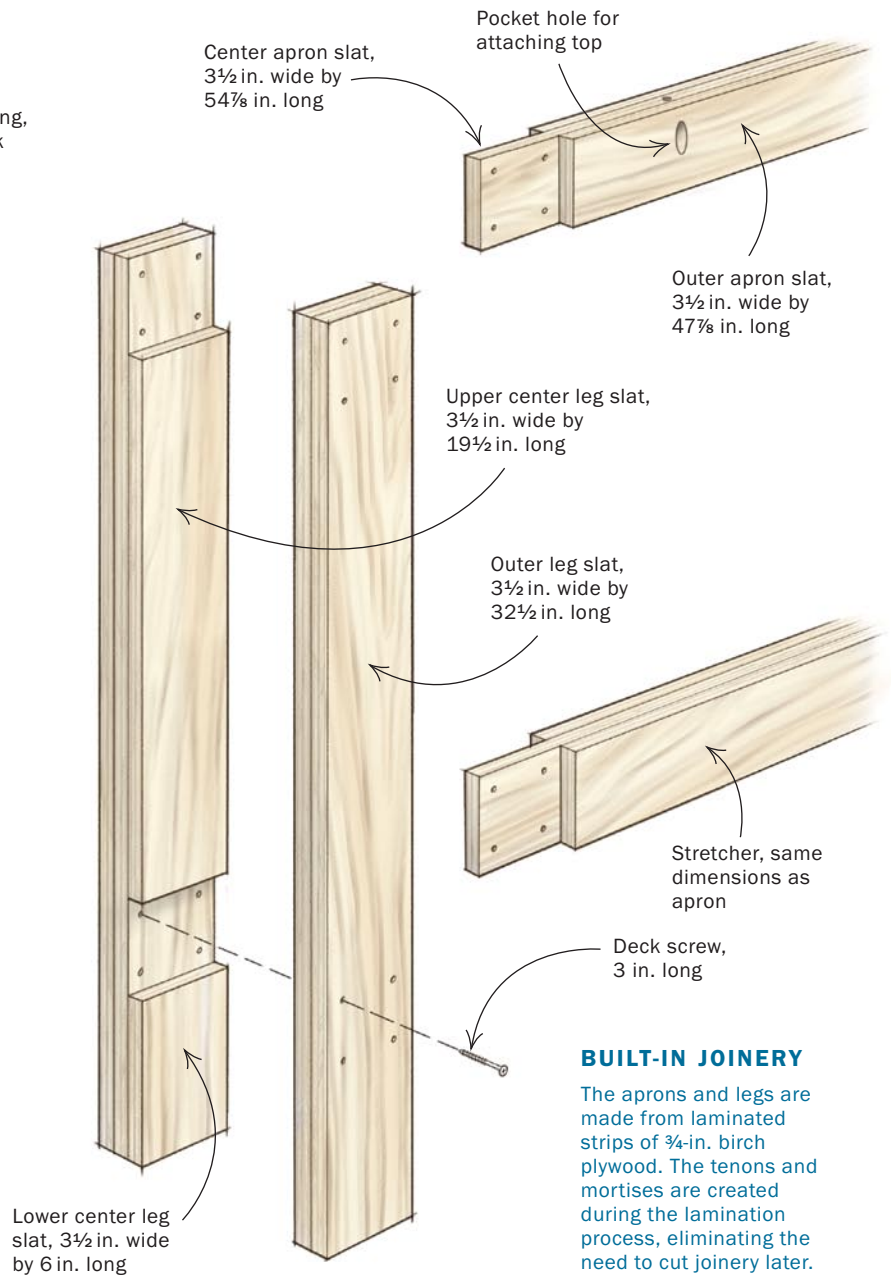

BUILT-IN JOINERY

The aprons and legs are made from laminated strips of 3/4-in. birch plywood. The tenons and mortises are created during the lamination process, eliminating the need to cut joinery later.

MAKE THE MOST OF YOUR PLYWOOD

If you decide to build a bench that is the same size as mine, or one that is slightly taller, or one that is slightly taller, use these cut plans. I used 2½ sheets of 4x8 birch plywood and a sheet of MDF from my local home center. Have your plywood seller make the first and second cuts as shown to ease handling the material.

Other materials needed are 2-, 2½-, and 3-in.-long deck screws, and a quart of fresh PVA woodworking glue. I've used both Titebond II and III, but particularly in hot, dry conditions, glues with extended open times make alignment of the laminations easier.

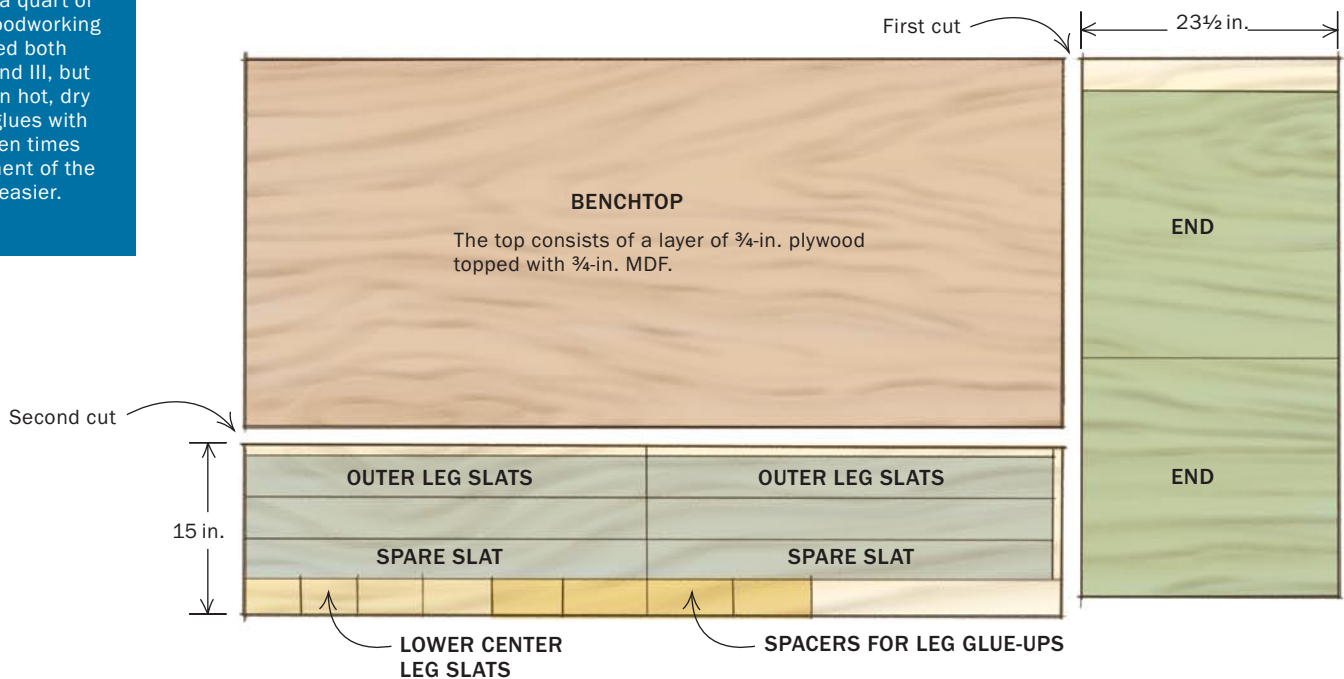
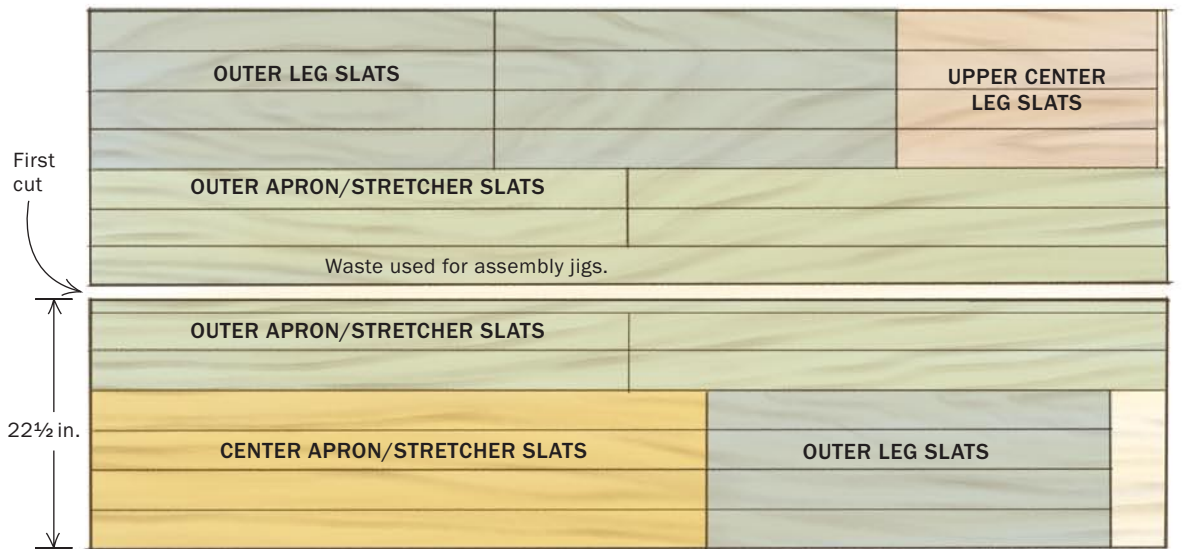

The two optional shelves come out of a half sheet of ¾-in.-thick plywood.

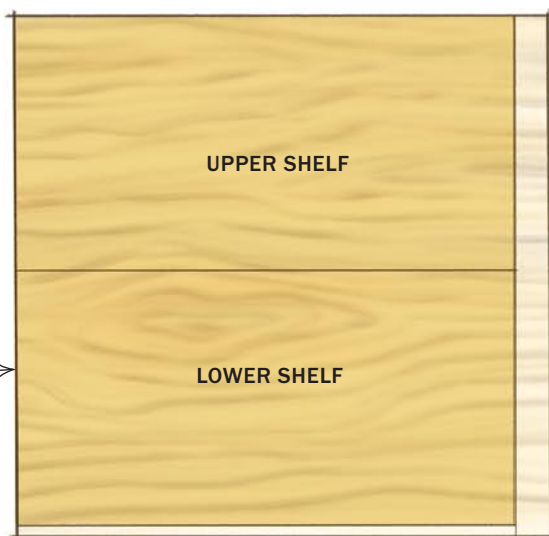

will get some tearout when you cut plywood: This can be minimized with a zero-clearance insert on the tablesaw, but in any case rip with the show side of the plywood up. If you do get some tearout, lightly sand away any splinters and keep the tearout side inward when assembling the components.

The last step before laminating the components is to drill pocket holes every 6 in. on one side of the two outer apron pieces to attach the top with pocket screws. Or you can use the battens described on p. 58.

Glue-up requires quick work, attention to detail

Even with glue that has a moderate amount of open time, you must work quickly, so do a dry run first and have all components in order. I apply the glue to all mating surfaces with a disposable brush that has the bristles trimmed, but a roller would work. Glue the laminates on a flat surface protected by waxed paper.



A SIMPLE JIG AIDS APRON ASSEMBLY

When gluing the stretchers and aprons, use a jig to align the center slat at the proper offset to create the tenon.

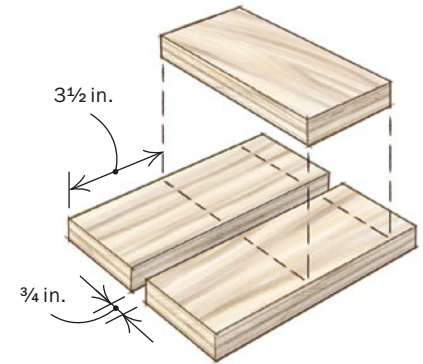

Construct the aprons and stretchers. These parts consist of a center strip of plywood that includes the two tenons, and two shorter outer strips that form the shoulders of the tenon. Have multiple clamps ready for use.

Assemble and glue stretchers and aprons—Make sure all like pieces are trimmed to exactly the same length. Draw a line $3\frac{1}{2}$ in. from both ends of the longer center-slat pieces, and mark the ends of both sides with an “X” to indicate non-glue areas. If you are using pocket holes on the aprons, make sure the holes are facing outward and upward.

Glue the three pieces of each component together, being careful not to get any glue on the tenon ends. Turn the assembly on edge so that the plies are facing up and insert one end in the apron jig (see drawing, top right). As you apply clamping pressure, keep the slats aligned and pushed against the jig to maintain the $3\frac{1}{2}$ -in. tenon and even cheeks. When the glue is dry, run both exposed-ply sides of each component through the tablesaw to clean them up.

Next, make the legs—Prior to assembly, make the spacer blocks (see photos, p. 58) and wrap about 5 in. of each with clear tape. Used to create the lower mortise on each leg, the spacer is driven out after the leg has dried. Tape prevents glue from sticking to the spacer. The leg stack consists of two outside slats, the lower center piece, the spacer, the upper center piece, and two more outside slats. Locate the upper and lower mortise areas and mark both mating surfaces so that you will remember not to apply glue there.

A simple L-shaped jig helps to lay up the legs accurately. Glue the slats together, remembering to in-

sert the spacer. After assembly, turn the stack so that the spacer is sticking up. Using both sides of the jig, keep the ends and edges of each slat in perfect alignment and the center slats pressed tightly against the spacer as you apply clamping pressure. Apply two small clamps to both outside pairs of slats that form the upper mortise.

After the glue has set, make cleanup cuts on the tablesaw. Use sandpaper to slightly chamfer the bottom edges of the finished legs to prevent splintering of the outer veneer if the bench is dragged across the floor.

Assemble the frame sides, then join them with plywood panels

Start by dry-fitting the tenon on each end of a stretcher into its respective mortise. If a tenon extends beyond the leg, trim it flush or slightly recessed. Lay a leg on a flat surface protected with waxed paper. Apply glue to the mortise-and-tenon, then insert the tenon and clamp lightly. Use a carpenter’s square to bring the stretcher and leg to exactly 90° , and tighten the clamp. Remove the excess glue with a damp cloth, put the joint aside to set, and assemble the second leg and stretcher.

Once the glue has set, remove the clamps and lay the leg/stretcher down with the inside facing up. Drill four countersunk pilot holes at least $2\frac{1}{2}$ in. deep into each joint and drive in waxed 3-in. deck screws. Reinforcing the joints in this manner may not be

Tip: Once you spread the glue you’ll have to work quickly, so do a dry run first and have all the components in order.



Leg assembly. Insert a taped spacer block to hold open the lower mortise. An L-shaped jig keeps the sections aligned. Use a generous amount of glue, but don't apply glue to those areas that face the spacer block.



Clamping the leg. When the sections have been glued together, turn the assembly upward and apply the clamps. Waxed paper protects the work surface. When the glue has dried, knock out the taped spacer block with a mallet and a thin piece of wood to reveal the mortise.



necessary, but it is very cheap insurance that the joints will hold forever.

Stand the assembly on the floor with the stretcher pointing up. Place waxed paper under the apron mortise; apply glue to the mortise and insert an apron tenon, being sure the pocket holes are oriented properly. Check for 90° and clamp the apron with a bar clamp. When the joint is dry, reinforce it with screws and then attach the other leg in the same manner.

The benchtop should rest on the aprons, not the legs, so if the top of a leg is higher than the apron tenon, trim it flush. Sand the exposed joints on the legs to remove glue residue.

If you are not using pocket screws to attach the top, prepare a couple of 2-in.-square battens with countersunk holes in two directions. Clamp the battens flush with the top inside edge of the aprons and attach them with 3-in. deck screws.

Stand the front and rear assemblies on their legs on a level floor, and cut two pieces of plywood to fit between the stretchers and aprons and to the desired width of the frame. These sides will serve as the end stretchers. There will be space to install an end vise above the side of the bench if desired. Chamfer the edges of the sides. Drill countersunk holes every 3 in., 1¾ in. in from both edges to locate the screws in the center ply of the legs. Clamp the sides in place with the edges flush with the outside edges of the legs. Be sure to check that the frame is square by measuring the diagonal between opposite corners; adjust until the



Clean up the edges. After the legs, aprons, and stretchers have been assembled, run both edges past a sawblade to clean up glue residue and leave them at the final 3½-in. width. Cut the first edges with the fence at 3⅛ in., and the opposite edges at 3½ in.

distances are even, then tighten the clamps. Now drill pilot holes 1½ in. deep through the previously drilled countersunk holes, and drive 2½-in. deck screws.

Next, add two plywood shelves, the lower one attached to the front and rear stretchers with 2-in. screws, and the upper one screwed to battens attached with 3-in. screws through the end stretchers into the legs. Because the shelves, sides, and top are screwed on, the whole bench can be disassembled for moving.

Make and attach the top

If you are making your own top, lay the layers upside down, making sure one end of the assembly is flush, and screw them together using countersunk screws that will not go through the top layer. Cut the other sides flush using a circular saw and straightedge or the tablesaw.

Ask a friend to help place the top on the frame and position as desired. Mark the corners of the legs on the underside of the top. Then turn the top over and mark the holes for the vise(s) on the bottom side so that you can drill small holes through. You may have to add a spacer block to bring the vise jaws level with the top. Turn the top back over and use a spade bit to drill recesses for the bolt heads at each of the small holes. Then drill for the bolts and attach the vise. At this point you can attach the top: Place it on the bench frame and secure it with the pocket holes or battens.

To protect the soft edge of the MDF top, I screwed a solid wood edging around the entire benchtop, leaving a gap for the vise. Drill holes for bench-dogs (if desired), and you are done. If you plan to use this bench primarily for glue-ups or finishing, a good choice would be to laminate the top; otherwise, apply a clear finish or just leave it natural. □

Cecil Braeden is a woodworker near Anacortes, Wash.



1

ASSEMBLING THE BASE

Begin with the frame

sides. Insert the stretcher and apron into the leg, making sure they meet at exactly 90° (1). Reinforce the joints with four 3-in. deck screws. With the side frame resting on the floor, add the second leg (2). Finally, add the plywood end stretchers (3). Clamp them in place, check the base for squareness, then attach with screws.

