

Ultimate Crosscut Sled

Achieve the accuracy
of a sliding tablesaw
for a fraction of the price

BY JOHN McCORMACK

With a bit of support at the outfeed end, most tablesaws excel at ripping—whether wide panels or long boards. Crosscutting these pieces is a different story.

Many commercial shops own large, industrial sliding-table tablesaws that make these cuts safely and accurately. But the options for a one-man shop on a limited budget are less attractive. Even an expensive aftermarket miter gauge has a relatively short stroke, and cutting steadily is difficult because of friction between the workpiece and the saw table. Many folks make a traditional carpenter's crosscut sled, with front and back hardwood fences and a pair of runners to engage the miter-gauge grooves. When accurate, these sleds are very useful, but the fences tend to warp and bow, and you have to shim them with masking tape. Another disadvantage is that these sleds lack a built-in measuring tape and stop system. The resulting cuts are seldom truly square or accurate. Last, the back fence limits the crosscut capacity.

A third alternative is to build this sliding crosscut sled that I first encountered at the Program in



LARGE PIECES AND REPEAT CUTS

Used in conjunction with the sled horse (p. 69), the crosscut sled can cut very large pieces safely and accurately. Crosscutting an 8-ft.-long piece of plywood is possible (left). The flip-stop on the sled's fence allows you to make accurate and repeatable crosscuts (right) on stock up to 56 in. long.



A NEW APPROACH

The triangular shape is designed to support large pieces yet minimize the weight of the sled, while the handholds make the sled easier to carry on and off the saw. The 36-in. miter bar gives the sled a similar crosscut capacity. The single bar rides in the left-hand miter-gauge slot, so with your right hand on the dedicated handle, your body is safely to the left of the blade, unlike with a carpenter's sled. The two-part fence is designed not to bow and has a flat face that can be adjusted if necessary. It is perfectly square to the blade. The sawkerf marks the edge of the sled, making for easy layout and splinter-free cuts. Finally, a track-mounted stop, keyed to a self-adhesive ruler, ensures precise, repeatable crosscuts.

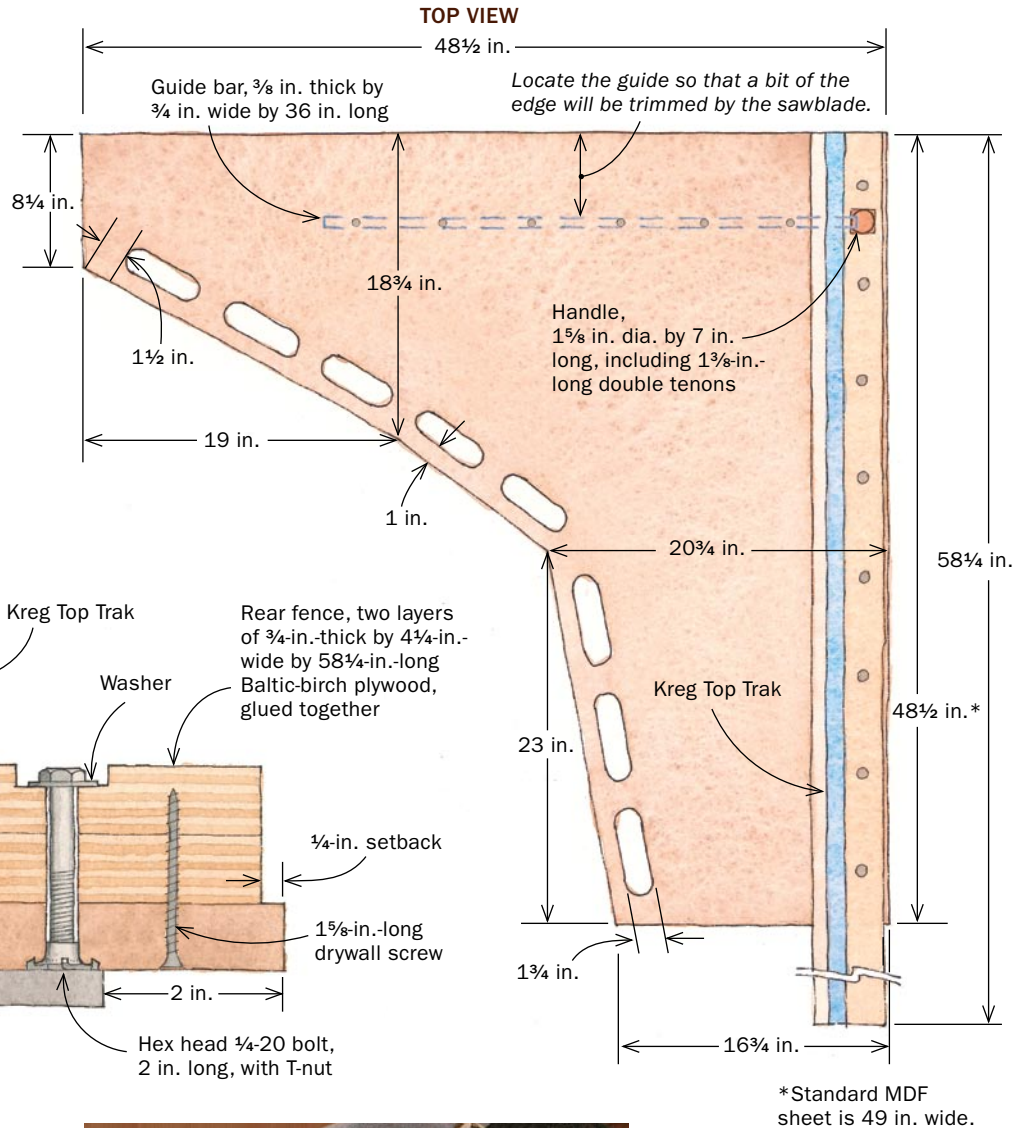
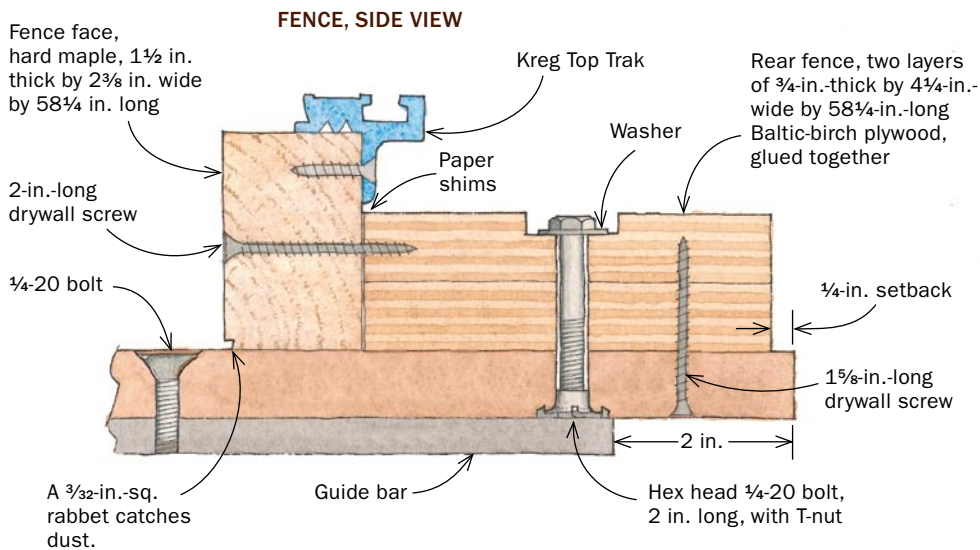

Artisanry at Boston University. Carefully made, it will crosscut large panels and long boards accurately, squarely, repeatably, and safely. This wide sled relies on extra support at its outboard end. On p. 69, I've included plans for a versatile sawhorse that will handle this job and many others.

Construct the bed and an adjustable fence

The bed of the sled is made from 3/4-in.-thick medium-density fiberboard (MDF), which is flat and durable. Cut the initial square on the table-saw, and then use a jigsaw to remove the triangular waste piece and make the cutouts. Round over the edges of the cutouts and just the upper edges around the perimeter. Keep the lower edges square to reduce dust getting under the sled.

Mark the location of the miter-slot bar so that the sled overhangs the sawblade position by 1/4 in. This will be cut flush once the sled is finished.

A plywood fence is screwed to the bed—To get perfectly square crosscuts on any length of wood, the fence must be absolutely straight over



Make the bed

Start with a square of MDF. Clamp it to a pair of sawhorses and cut away the waste section.



Cut out the handholds. Multiple handholds make it easier to maneuver the bulky sled on and off the saw, and also slightly reduce the weight.

Add the fence and guide bar

1 ATTACH THE REAR PART OF THE FENCE

Locate the fence. After drilling holes in the rear section of the fence, square it to the bed, clamp it, and tap a drill bit with a hammer to mark the location of the holes.

BOLT THE REAR FENCE TO THE BED

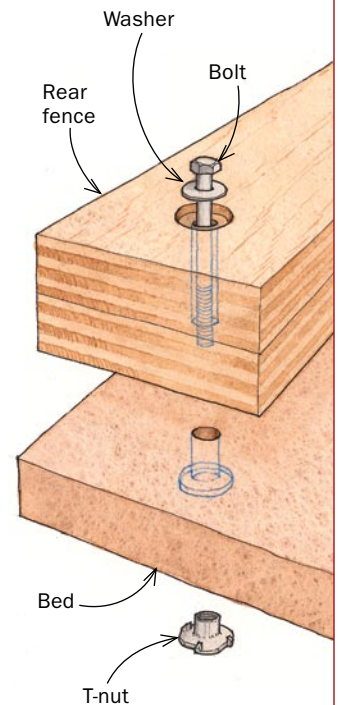

Customize the nuts for MDF. Designed to penetrate wood, the long spurs on the T-nuts need to be shortened to go into MDF. Attach a nut and a T-nut to one of the bolts used to secure the plywood fence to the bed of the sled. Working on the left-hand side of the T-nut so that the force pushes the nut onto the bolt, gently grind away about half of each spur.



its length. To achieve this, the fence has two parts: a plywood rear section that is screwed to the bed of the sled, and a hardwood face that is added later. The rear piece gives the fence its stiffness. It consists of two layers of 3/4-in.-thick Baltic-birch plywood laminated into a 1 1/2-in.-thick by 4 1/4-in.-wide bar. True this up after lamination.

Lay out the fence-attachment holes so they miss the location of the miter-gauge bar. Using a Forstner bit, counterbore 7/8-in.-dia. holes, 5/16 in. deep, into the top of the fence. Then use a brad-point bit to bore 5/16-in.-dia. holes through these counterbores and through the fence.

Lay the fence on the sled table 1/4 in. from the edge nearest the operator. That way, if the sled is knocked, the blow is absorbed by the bed and won't knock the fence out of alignment. Square the fence to the line marking the location of the guide bar, and clamp the fence to the sled table. Place the 5/16-in.-dia. brad-point bit in the fence holes and tap the bit with a hammer to transfer the location to the MDF. On a drill press with a fence, use a 1/16-in.-dia. bit to transfer the hole location to the underside of the sled. Turn over the bed and use a 1-in.-dia. Forstner bit to counterbore 3/32-in.-deep holes for T-nuts. Finally, bore all the way through the MDF with the 5/16-in.-dia. bit.

Before you attach the fence to the bed, you need to add a handle located right

over the miter-gauge bar. I turn my handle on a lathe and double-tenon it into the fence, but you also can use a thick dowel glued into a drilled hole. Make sure the handle is far enough back on the fence so the flip-stop (added later) will slide by.

The fence is attached to the bed with 1/4-20 bolts screwed into T-nuts sunk into the recesses in the bottom of the bed. Because the spurs on the T-nuts are designed to bite into wood, shorten them on a grinder so they'll work on MDF (see photos, above).

Add the guide bar—Turn the sled over so that both the fence and the location of the guide bar overhang the bench. The guide bar is attached to the bed with machine screws, but this involves drilling and tapping holes in the bar. If you've never done this, I suggest using a piece of extruded aluminum for the bar. Relatively soft, it drills and taps easily, but because the tolerances are less than for steel, you will have to dimple one side to create a tight fit in the miter slot. Mild steel is harder to drill



Attach the fence. Tap the T-nuts into the underside of the sled, slide 1/4-in.-dia. bolts through the fence, and then use a socket wrench to drive the bolts into the T-nuts.

2 ATTACH THE GUIDE BAR



Drill and tap the guide bar. McCormack uses a #7 drill and then taps the bar to take 1/4-20 machine bolts.



A machinist's trick

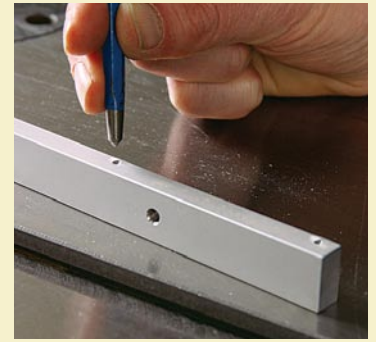

To create a tight fit in the miter slot, use a center punch to create dimples on the side of the guide bar nearest the blade. Place dimples 1/8 in. from the top of the bar, starting 1/4 in. from the ends and spaced every 3 in. File the dimples to fine-tune the fit.

and tap but will wear better. Both bars are available at www.onlinemetals.com (aluminum, part No. 6061 T6; steel, part No. 1018 CF). Clamp the bar at the location you marked earlier, drill through both bar and sled, and then tap them with a 1/4-20 tap. With the bar still clamped, working from the underside, countersink the holes on the top of the sled and screw flat-head machine screws through the sled into the bar.

The second part of the fence, the hardwood face, gets a 3/32-in.-sq. rabbet on its bottom front edge so dust can collect there instead of pushing the workpiece out of alignment during multiple cuts. You also

need to drill and countersink holes in the face to attach it to the plywood back.

The top of the fence face receives a Kreg Top Trak, which comes in 4-ft. and 2-ft. lengths. You'll need two sections of track to extend the length of the 5-ft. fence. Drill and countersink holes along the track and attach it to the fence face with wood screws. Clamp the two sections of fence together, place shims between them to ensure that the face is dead flat, then screw them together.

Adjust the fence to cut square

Make the first cut on the sled to trim away the 1/4-in. overhang on the bed and the

fence. Then, to square the fence, make test cuts on a 2-ft.-wide by about 20-in.-long plywood panel. The panel needs a true edge to ride against the fence face, so hand-plane or edge-joint it dead straight. Make the first crosscut, flip the panel 180°, and cut the opposite side with the true edge of the board still against the sled fence and then at the far end of the board. If the fence is not at 90° to the sawblade, this test cut will double the observable error.

If the second measurement is greater than the first, you are cutting at more than 90°. Put a fine pencil mark on the sled's bed in

3 ADD THE FACE OF THE FENCE



A straight fence. Clamp the two sections of fence together, and use pieces of paper as shims until a straightedge verifies that the front of the fence is perfectly straight.



Join the two fences. Once you're certain the face of the fence is straight, use 2-in. drywall screws to attach it to the back section of the fence.

Square the fence

The first cut. With the fence and miter bar attached, you can trim the bed flush with the blade. If you push the sled into the blade, very little of the miter bar is engaged in the slot at the start of the cut. It is safer to raise the blade through the first few inches of the sled.



front of the face, unlock all but the right-hand attachment bolt, and rotate the fence slightly clockwise. The $\frac{1}{4}$ -in. bolts in the $\frac{5}{16}$ -in.-dia. holes give you enough play. If the second measurement is less than the first, rotate the fence counterclockwise. Relock the fence and make two new test cuts. Keep adjusting until you are cutting a true rectangle. Then drive countersunk drywall screws through the underside of the bed into the plywood fence.

Apply a strip of right-to-left self-adhesive rule to the Top Trak, and then calibrate the cursor on the Kreg flip-stop.

Safe operations while using the sled

You are now ready to make perfect, square crosscuts and cut boards to the same length time after time. However, you should take precautions if you work near the capacity

TEST CUTS ENSURE THE FENCE IS SQUARE



The first cut. Take a piece of plywood, about 20 in. sq., with one side perfectly straight. Place this side against the fence, mark the opposite side with a triangle, and cut one of the adjacent sides using the sled.



The second cut. Flip the test board 180°, keeping the same side against the fence, and cut the side opposite the first cut.



Measure the difference. Measure the width of the board adjacent to the fence and at the opposite end. If there is a difference, the fence isn't perfectly square to the blade.

Adjust the fence. There is a small amount of play in the bolt holes. Place a pencil mark on the bed of the sled next to the fence, loosen all but the right-hand fence bolt, and pivot the left-hand end of the fence forward or backward. Tighten all the bolts and make another pair of test cuts.



limits of the sled. When making a wide offcut, use a catcher keyed into the right-hand miter gauge and sitting level with the sled. This will support the offcut and prevent tearout near the end of the cut.

If you crosscut at the maximum width, be very careful that the sled does not see-saw out of the miter-gauge groove at the start of the cut, causing the sled and the workpiece to kick back. You'll also find it helpful to have an outfeed table for your saw; otherwise the sled could fall off at the end of the crosscut. It's a good idea to hang the sled on the wall when not in use so that it doesn't get damaged. □

John McCormack is a furniture maker and woodworking teacher in San Francisco, Calif.

Build an adjustable sawhorse

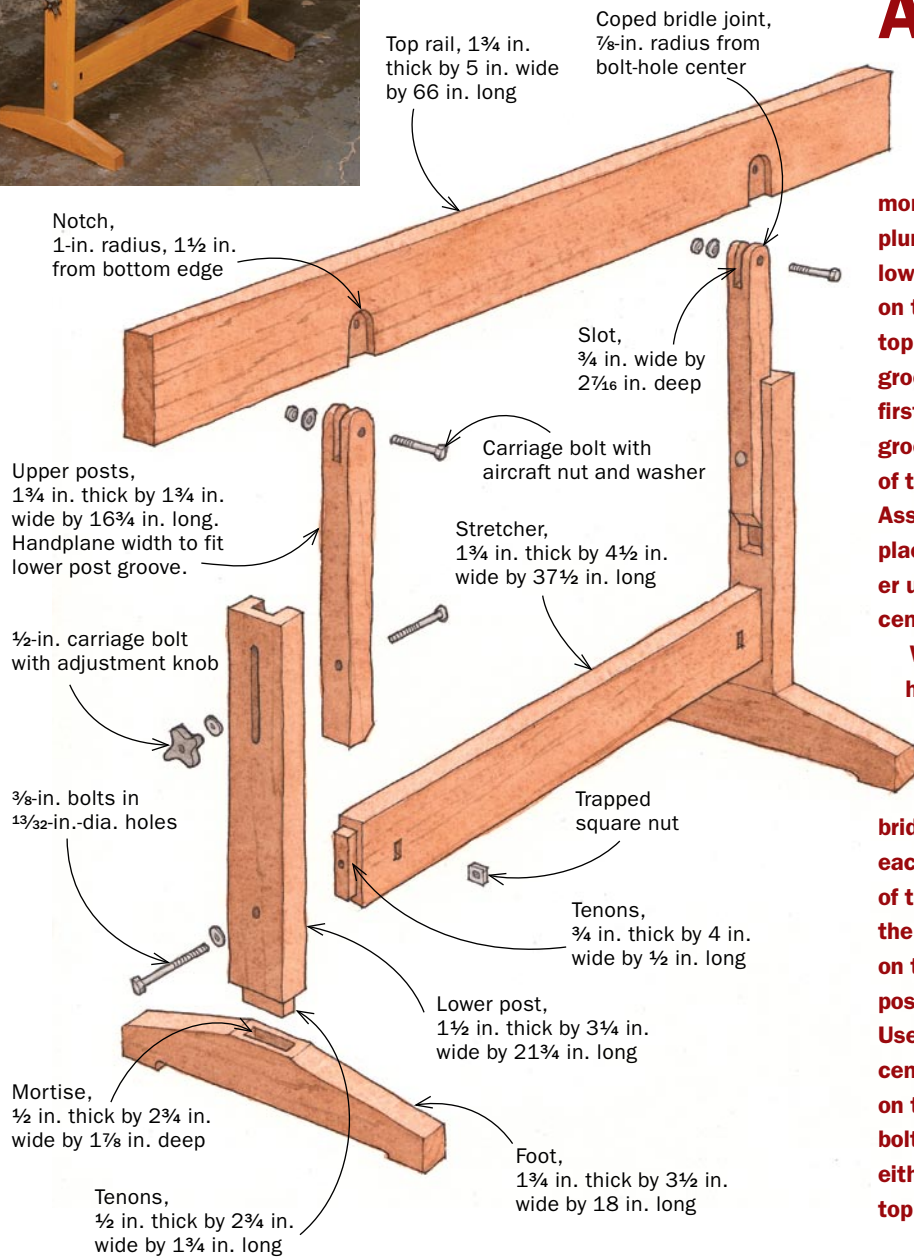

Although designed to be used with the crosscut sled, this sawhorse, or a pair of them, finds numerous uses in my shop. Finish-mill the parts to the correct dimensions, but leave the upper posts 1/32 in. extra thick to be fit to the lower post grooves later. Lay out and cut the trestle-foot mortises, using either a hollow-chisel mortiser or a plunge router, and then cut and fit the tenons on the lower trestle posts. Bandsaw the reliefs and tapers on the feet. Lay out the height-adjustment slots in the top outside faces of the lower posts, and the stopped grooves on the top inside faces. Plunge-rout the slots first, only just deeper than needed. Then dado the grooves and chop them square. Clean up the surfaces of the lower posts and feet, and glue them together. Assemble them to the stretcher and clamp them in place. Bore the holes for the bolts in the lower stretcher using the hole in the post as a guide, aiming for the center of the nut mortise.

With the base assembled, you can work on the top half. Handplane, scrape, or sand the upper posts to fit the stopped grooves in the lower posts. Bore holes for the 1/2-in.-dia. carriage bolts and chop the square relief for the bolt shank. The coped bridle joints allow the upper rail to pivot if the height of each leg needs to be different. Lay out the female part of the coped bridle joint on the upper post and bore the top ends for the 5/16-in.-dia. bolt. Cut the bridle joint on the table saw and round the ends. Attach the upper posts to the lower base with 1/2-in.-dia. knobs and bolts. Use the tight structure to lay out the location of the centers of the two male parts of the coped bridle joint on the lower edges of the upper rail. Bore the 5/16-in.-dia. bolt holes first, and then plunge-rout away the waste on either side of the male part of the bridle joint. Wax the top rail, assemble the horse, and put it to use.

Set up the sled horse. Use a level to ensure that the top rail of the horse is even and parallel with the top of the table-saw. The coped bridle joints allow the horse to be used on uneven floors.



Mark its position. Once you have the sawhorse set, mark the point where the stiles meet, and where the feet are located on the floor. Now you can use the horse elsewhere and reset it quickly.



Locking blocks. If you are worried about the combined weight of the sled and a heavy workpiece causing the horse to shift, clamp a custom-size block into the gap below the upper stile.